

# Coyote<sup>®</sup> UW<sup>®</sup> Amalgam Series

Ultraviolet Water Treatment System

## INSTALLATION, OPERATION AND MAINTENANCE MANUAL



**KEEP THIS MANUAL ON HAND**

**IMPORTANT:** Anyone responsible for installation, maintenance or operation of this equipment must have a thorough understanding of the instructions and safety requirements before attempting to install or service this system.



*One Source for All Your UV Needs!*



Dear Customer:

Thank you for selecting UV Superstore, Inc. to provide the equipment for your ultraviolet water treatment needs. The CoyoteUV® Series is an American Made, in-house engineered design built with the customer in mind. These systems deliver Disinfection, TOC reduction or Ozone destruction. Your CoyoteUV® system reflects our broad experience in UV water treatment and our commitment to quality craftsmanship. When properly installed and maintained, your UV Superstore, Inc. equipment will provide years of reliable service.

Please review the Owner's Manual carefully and keep it on hand for readily available assistance. UV Superstore, Inc. designs its models for service maintenance ease. The manual provides essential information to safely install and service your system.

UV Superstore, Inc. manufactures ultraviolet equipment with the highest quality components available. Your equipment has met thorough testing procedures ensuring the efficiency of your system. As with any equipment regular maintenance procedures are required. You will have to replace your UV lamps and other items from time to time. UV Superstore, Inc. offers a complete line of replacement parts, not only for your products, but for most lines of ultraviolet water treatment equipment. Please call us for details.

UV Superstore, Inc. has built an industry-leading reputation by providing a reliable and knowledgeable technical support team. We stand by ready to assist you in all of your UV water treatment needs. Please contact us with any questions you may have regarding your system.

Best regards,

The UV Superstore Team



*One Source for All Your UV Needs!*

# Table of Contents

|   |           |
|---|-----------|
| <b>Safety Instructions</b> .....                          | <b>1</b>  |
| <b>1) Information</b> .....                               | <b>2</b>  |
| <b>2) About Ultraviolet (UV) Disinfection</b> .....       | <b>2</b>  |
| <b>3) Major Components</b> .....                          | <b>3</b>  |
| a) <i>Disinfection Chamber</i> .....                      | 3         |
| b) <i>Electronic Control Center (ECC)</i> .....           | 4         |
| c) <i>Lamp and Quartz Sleeve Inspection</i> .....         | 5         |
| <b>4) Preparation For Installing UV System</b> .....      | <b>6</b>  |
| a) <i>Water Quality</i> .....                             | 6         |
| b) <i>Important Safety Information</i> .....              | 6         |
| c) <i>Optimizing System Performance</i> .....             | 7         |
| d) <i>Environmental Issues Relating to UV Lamps</i> ..... | 7         |
| e) <i>Receiving UV Equipment and Spare Parts</i> .....    | 7         |
| f) <i>Electrical Configuration</i> .....                  | 7         |
| <b>5) Installation</b> .....                              | <b>8</b>  |
| a) <i>Wiring your Unit</i> .....                          | 8         |
| b) <i>Chamber</i> .....                                   | 8         |
| c) <i>Quartz Sleeve Installation</i> .....                | 8         |
| d) <i>Lamp Installation</i> .....                         | 12        |
| <b>6) Operation and Monitoring</b> .....                  | <b>13</b> |
| a) <i>Electronic Control Center (ECC)</i> .....           | 13        |
| 1. <i>Lamp Status</i> .....                               | 13        |
| 2. <i>Runtime Monitoring</i> .....                        | 14        |
| 3. <i>Viewport</i> .....                                  | 14        |
| 4. <i>UV Monitor (Optional)</i> .....                     | 14        |
| 5. <i>High Heat Sensor (Optional)</i> .....               | 17        |
| <b>7) Maintenance</b> .....                               | <b>18</b> |
| a) <i>Lamp Maintenance</i> .....                          | 18        |
| b) <i>Quartz sleeve Maintenance</i> .....                 | 18        |
| c) <i>Viewport Maintenance</i> .....                      | 19        |
| d) <i>Sensor Probe Maintenance</i> .....                  | 19        |
| e) <i>ECC Maintenance</i> .....                           | 19        |
| f) <i>Chamber Maintenance</i> .....                       | 19        |
| <i>Chamber Break Down—Removal of Heads</i> .....          | 20        |
| g) <i>High Heat Maintenance</i> .....                     | 21        |
| <b>8) Water Sampling (Flange Models)</b> .....            | <b>22</b> |
| a) <i>Sampling Valves</i> .....                           | 22        |
| b) <i>Sampling Procedure</i> .....                        | 22        |
| <b>General System Specifications</b> .....                | <b>23</b> |
| <b>Replacement Parts List</b> .....                       | <b>24</b> |
| <b>FDA Statement</b> .....                                | <b>26</b> |
| <b>Heat Sanitization</b> .....                            | <b>27</b> |
| <b>Maintenance Log</b> .....                              | <b>28</b> |
| <b>Dimensional Drawings</b> .....                         | <b>30</b> |
| <b>Troubleshooting</b> .....                              | <b>32</b> |
| <b>Warranty Information</b> .....                         | <b>33</b> |
| <b>Wiring Diagram Pullout</b>                             |           |

## SAFETY INSTRUCTIONS

In order to protect end users and operators from injury, safety precautions must be followed. This installation, operation and maintenance manual outlines important safety issues. The following **WARNING SYMBOLS** will be found throughout the manual to alert the end users to take important precautions:



### **EYE PROTECTION**

This symbol indicates that eye protection must be worn to protect from UV light as well as debris.



### **HAND PROTECTION**

This symbol signifies that hand protection must be worn to protect the lamps from skin oils as well as protect the operator from UV light and sharp materials caused by a broken lamp/quartz.



### **ELECTRIC SHOCK**

This symbol signifies electrical shock possibility.



### **CAUTION**

This symbol indicates a potentially dangerous situation. Failure to adhere to this warning may lead to serious injury and/or death.



### **INFORMATION**

This symbol signifies helpful information.

## 1) Information



Please read this manual prior to installing, starting up and operating the equipment. The equipment uses the latest in UV technology, but has been designed to make operation and maintenance easy.

The quality of the liquid entering the UV system needs to be monitored. Based on your water quality, the UV system will need to be cleaned on a periodic basis. Maintenance of the UV system will require replacement parts. It is suggested that key spare and replacement parts be kept on hand. For best operation, it is recommended to use the correct replacement parts. Incorrect replacement parts could result in damage to the system and void the warranty.

## 2) About Ultraviolet (UV) Disinfection

The technology uses UV light to target and disable disease-causing microorganisms (pathogens).

Over 100 years ago, scientists discovered that if you exposed pathogens to UV light, their reproduction was limited. The UV light source that they used, resided in the UVC range of the light spectrum. Specifically, they discovered that light in the 254 nanometer (NM) range was the most effective wavelength for this process.

When many pathogens are exposed to UV light, their cells become damaged and this damage inhibits reproduction. The UV light, produced by a special UV lamp, damages the cell's DNA and RNA and once damaged, they are unable to replicate. This physical process renders them harmless. The amount of damage is a result of the intensity of the UVC output multiplied by the time the pathogens are exposed to the light. The applied dosage is commonly referred to as microwatt seconds per square centimeter or millijoule per square centimeter and is often expressed as  $\mu\text{Ws}/\text{cm}^2$  or  $\text{mJ}/\text{cm}^2$ . Most industrial applications require a dosage of  $30,000 \mu\text{Ws}/\text{cm}^2$  or  $30\text{mJ}/\text{cm}^2$ .

*Why are plants and operators selecting UV technology?*

- a) UV is considered a green technology
- b) No chemicals are added, so there is no need for chemical removal
- c) No chemical storage
- d) UV works instantly without requiring a residence time
- e) Easy maintenance

### 3) Major Components

The UV disinfection system will come with a number of components.

The following list highlights the main ones:

- a) Disinfection Chamber (aka vessel)
- b) Electronic Control Center (ECC)
- c) Ultraviolet Lamps and Quartz Sleeves

#### ***a) Disinfection Chamber***

The chamber is manufactured from high-grade 316L stainless steel. The vessel has been passivated and electropolished to protect the vessel against aggressive high purity water.

The chamber has an inlet/outlet connection, drain, sampling (with flange models only), and monitoring ports.

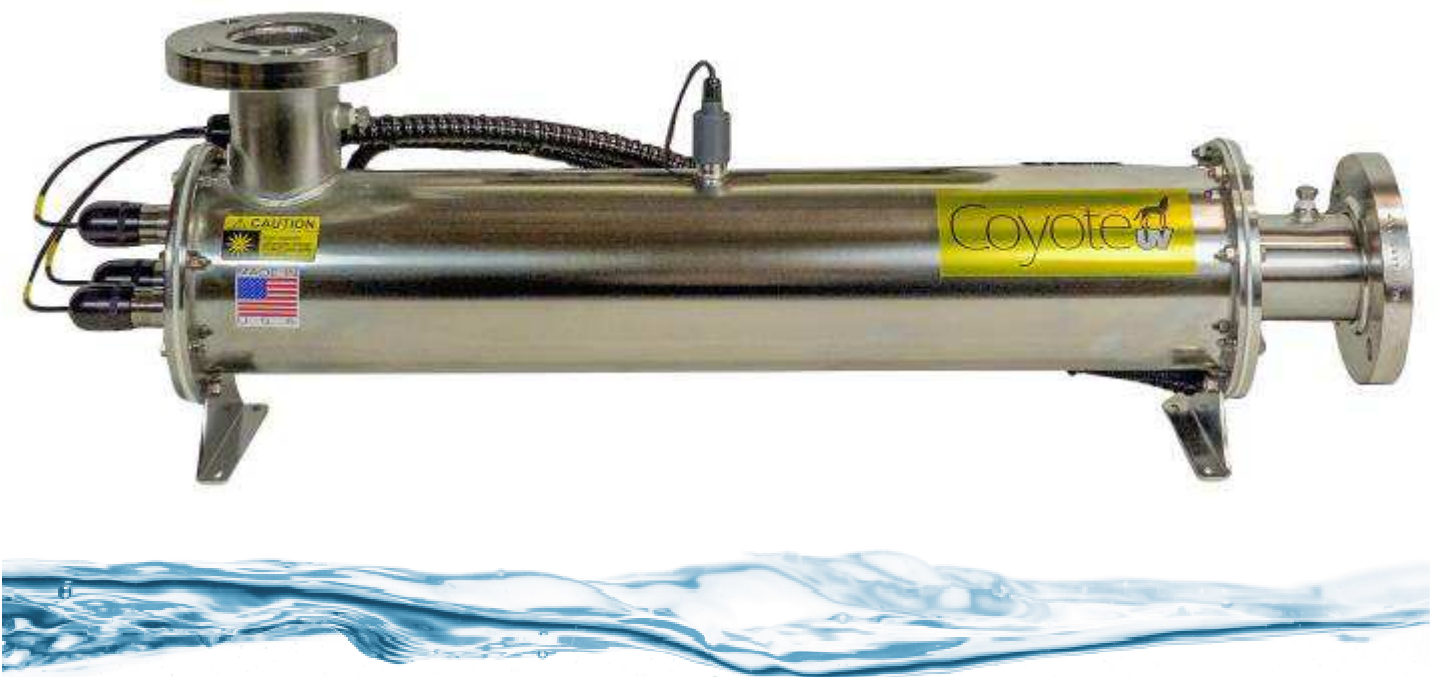

## b) Electronic Control Center (ECC)



The ECC is designed to be remote mounted within 4-6 feet of the chamber. Prior to final placement, ensure that the supplied cable lengths (8 ft.) are adequate to reach between the ECC and the chamber.

The ECC requires clean power. Information on voltage and cycle will be on the wiring diagram inside the ECC cover. Equipment should be kept off lines where there are surges or brownouts. Always disconnect power before servicing the system.

The ECC will contain the ballasts and other electrical controls. The ECC will display operation status such as individual Lamp Indicator, Elapsed Runtime Meter (ERTM), optional UV Monitor Intensity, optional Low UV Indicator, and optional High Heat indicator.

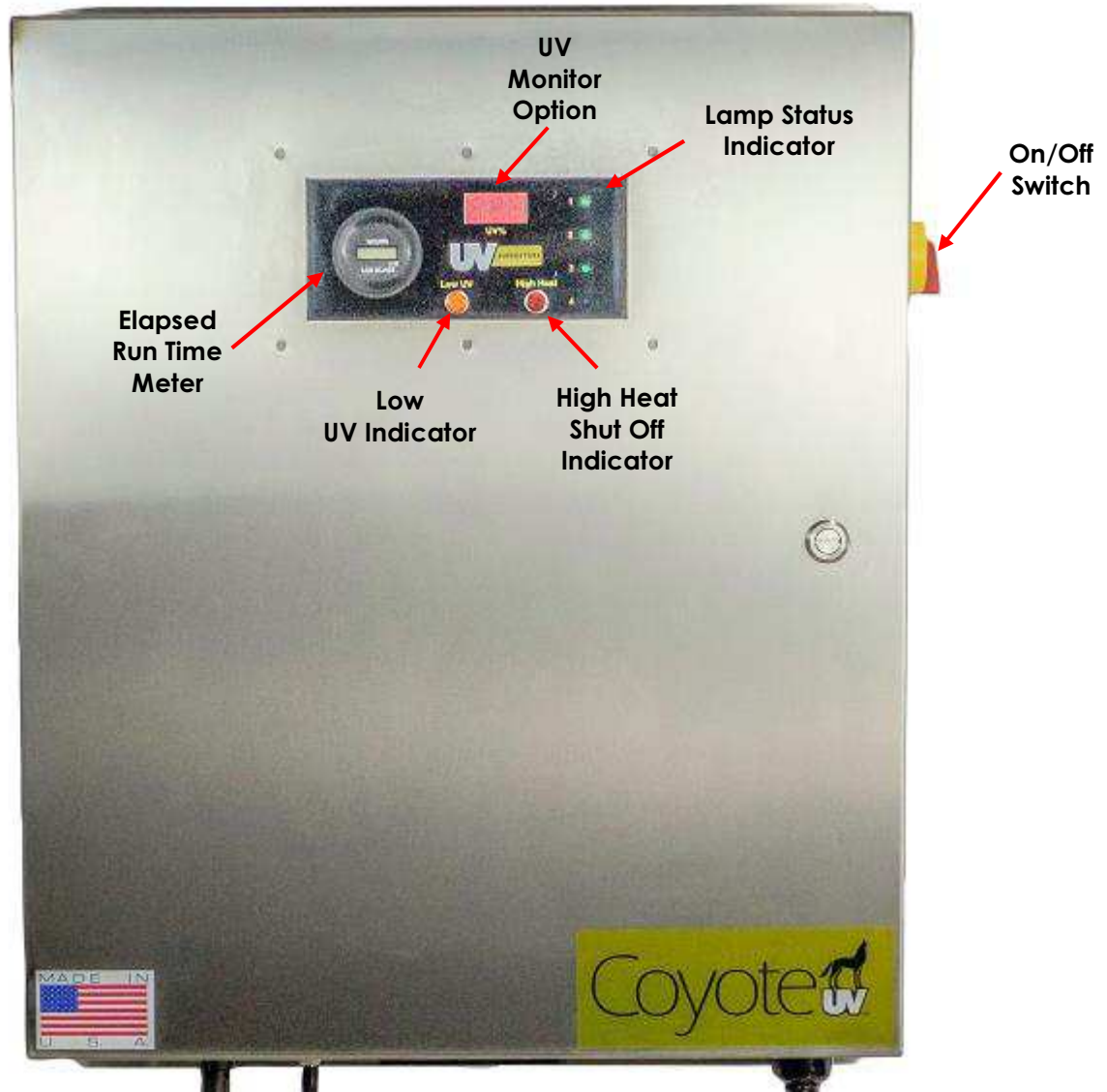



### ***c) Lamps and Quartz sleeves Inspection***

Use cotton gloves when handling lamps and quartz sleeves to prevent them from becoming dirty. If you break the lamps or quartz sleeves, take extra care to prevent yourself from becoming injured.

If damage has occurred during shipment, please put to the side in the original packaging and contact manufacturer. A claim will have to be made immediately to the shipping company.

## 4) Preparation for Installing UV System



The following information is meant to be used by engineers, contractors, operators and owners to help better understand the technology, its' benefits and potential hazards.

### a) Water Quality

For optimum performance of your UV system, water quality is extremely important. Proper pretreatment is essential for the UV disinfection system to operate as intended.

UV disinfection dosages are dependent upon the quality and clarity of incoming water. Impurities in water can interfere with UV intensity and cause dosage to fall to unsafe levels. Have your water tested to determine it meets the standards in the below table. If any of the elements exceed the maximum levels shown in the table, contact your water professional for recommendations for proper pretreatment.

The following table shows levels that are recommended for installation:

| Element          | Recommended Maximum Levels (1mg/L=1ppm) | Actual Value |
|------------------|---|--------------|
| Turbidity        | <5 NTU                                  |              |
| Suspended Solids | <5 mg/l                                 |              |
| Color            | None                                    |              |
| Iron             | 0.3 mg/l                                |              |
| Manganese        | 0.05 mg/l                               |              |
| pH               | 6.5 to 9.5                              |              |
| Hardness         | <120 ppm                                |              |

### b) Important Safety Information



UV lamps and their quartz sleeves can become razor sharp if broken. Take care when installing and removing the quartz sleeves. Only hand-tighten compression fittings. Do not use wrenches or other tools.

|  |  |
|--|--|
|  | <p>UV light is extremely harmful to eyes and skin and will cause burns. Do not look directly or indirectly at the UV light. Do not expose your skin for any prolonged time. Use protective clothing and eyewear (make sure it is UV resistant) when servicing equipment. If accidentally exposed to UV light for an extended period, immediately seek medical attention. Symptoms for eye exposure include burning, itching and redness. Symptoms for skin exposure are similar to sun burn.</p> |
|  | <p>Use cotton gloves when handling lamps and quartz sleeves. Skin oils will adhere to the lamps and sleeves and prevent UV light from properly emanating. If the sleeves become dirty, wipe them with a lint free cloth with denatured alcohol.</p>  |

### **c) Optimizing System Performance**

The UV lamps and their corresponding quartz sleeves need to be maintained. As a general rule, the lamps need to be changed after a year of usage (10,000 hours). Quartz sleeves should be changed every three (3) to five (5) years or sooner if damaged.

Quartz sleeves also need to be cleaned on a periodic basis based on real world plant conditions. The factory recommends using denatured alcohol or a commercially available non-abrasive cleaning product. In addition to cleaning, please remember to wear gloves when handling lamps and sleeves. It is important that the cleaning product you select leaves no residue.

### **d) Environmental Issues Relating to UV Lamps**



UV lamps need to be recycled like fluorescent lamps because they contain mercury. Please follow your local recycling laws. Please visit [www.lamprecycle.org](http://www.lamprecycle.org) for help finding a recycling center in your area. In the event that you are unable to find a disposal location, please contact manufacturer's representative.

### **e) Receiving UV Equipment and Spare Parts**

Inspection of the UV equipment must be made immediately upon receipt for damage and verification of contents. It is important to compare the contents of your shipment to the actual packing list. Any deviations must be brought to the factory's attention. Additionally, lamps and quartz sleeves need to be inspected for damage. If shipment or parts are damaged, immediately contact factory and hold broken contents and their containers for inspection by shipping company. Failure to make a damage claim within 2 business days of receipt of product can result in loss of claim.

### **f) Electrical Configuration**

The UV disinfection system uses sophisticated electronics and specialty lamps. The UV system's electronics require clean power. The system has been designed to use a certain specified voltage. UV equipment must be protected from surges. If the plant is susceptible to brownouts, please contact factory .

## 5) Installation

Qualified professionals (contractors, plumbers and electricians) should install the mechanical and electrical components as per code as per the engineering documents.

### a) Wiring your Unit

Make sure power to the equipment matches the voltage requirements of the system. Make sure the system is properly grounded. For complete wiring instructions, see wiring diagram inside the electrical enclosure. There is also a pullout in the back of this manual.

#### To provide power to the Electrical Enclosure for 120V:

1. To make installation easy, first remove the wire duct cover to install incoming power wires.
2. Locate the power connection point and install your incoming 120V power wires to the breaker.
3. Connect ground wire to the ground bar.

#### To provide power to the Electrical Enclosure for 220V:

1. To make installation easy, first remove the wire duct cover and unscrew the display plate (this does not need to be removed completely) to access the circuit breaker to install incoming power wires.
2. Locate the power connection point and install your incoming 220V power wires through the strain relief on the bottom of the enclosure to the breaker.
3. Connect ground wire to the ground bar.
4. Turn the breaker on.
5. Mount the display panel back onto standoffs and reapply the wire duct covers.

### b) Chamber

Ensure that you have adequate space on the lamp side of the vessel to insert and remove the quartz sleeve and UV lamp(s) (40" or more is preferred). If thought is not given to this aspect, the lamps and quartz sleeves will be impossible to install.

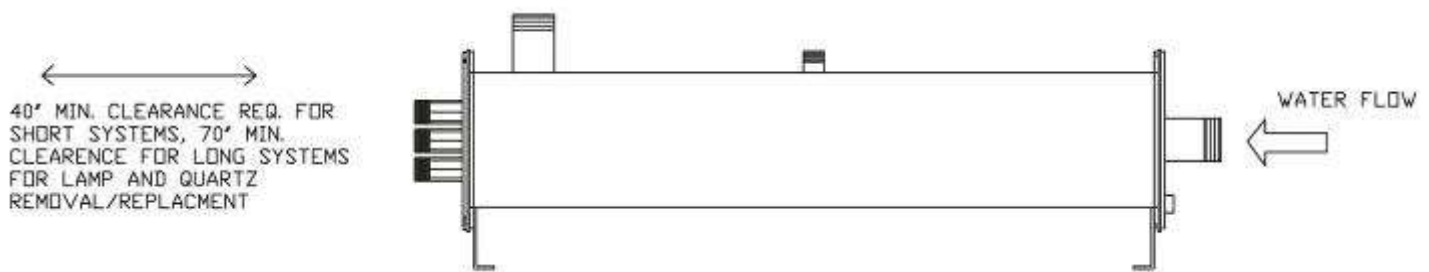

### c) Quartz sleeve Installation for closed sleeves (domed)

When working on this task, a single operator is appropriate.



The quartz sleeves seal by using a compression nut and compressing an O-Ring. This task requires no tools. Use cloth gloves to handle quartz sleeves and UV lamps to avoid putting fingerprints on the sleeves and lamps.

The compression nut has various features designed to provide a watertight seal. It has a stop ridge to securely hold the sleeve in place, an O-Ring cavity to hold the O-Ring, and an O-Ring bevel to properly seat the O-Ring between the nut and sleeve to make the seal.

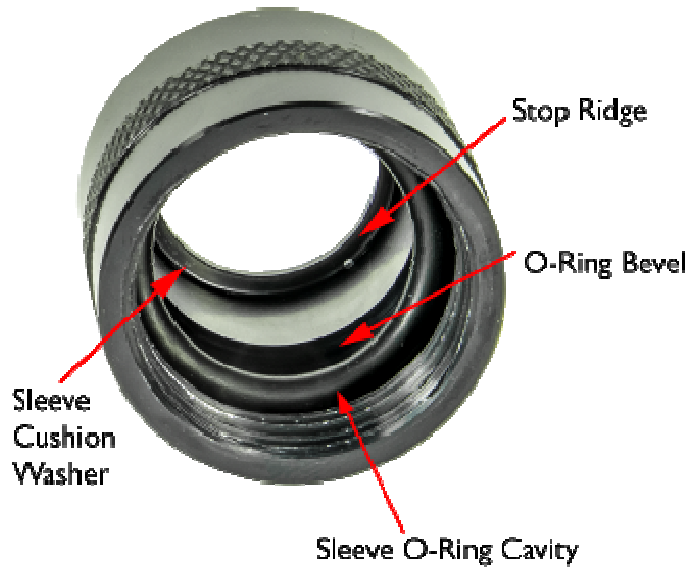

First, place the O-ring onto the end of the quartz sleeve as shown below.



**Note: The O-ring should slide down the quartz sleeve about 1/4". More than 1/4" can make installation more difficult.**



Next, insert the compression nut over the O-ring and quartz sleeve until it snaps into place. A slight rocking back and forth of the compression nut over the O-Ring will help this seat into place. The O-Ring should be around the sleeve inside the compression nut. If not, remove the compression nut and repeat process.

**Note: Once seated in place, you should be able to turn the compression nut freely.**



The lamp/quartz support plate supports the sleeve at the far end. The support sleeve has EPDM grommets to receive and cushion the quartz sleeve to prevent breakage during operation. Locate the grommet by feel and insert the sleeve until it just seats into the grommet.



It is recommended to familiarize yourself with your specific unit and the location of the lamp support plate and grommet(s). This can be accomplished by using a flashlight to look through the nipple(s) and locate the grommet(s).

To avoid breakage, the quartz sleeve must be in the corresponding grommet.

Prior to tightening down the compression nut make sure the quartz sleeve is in the correct location on the lamp support plate.

### Lamp/Quartz Support Plate

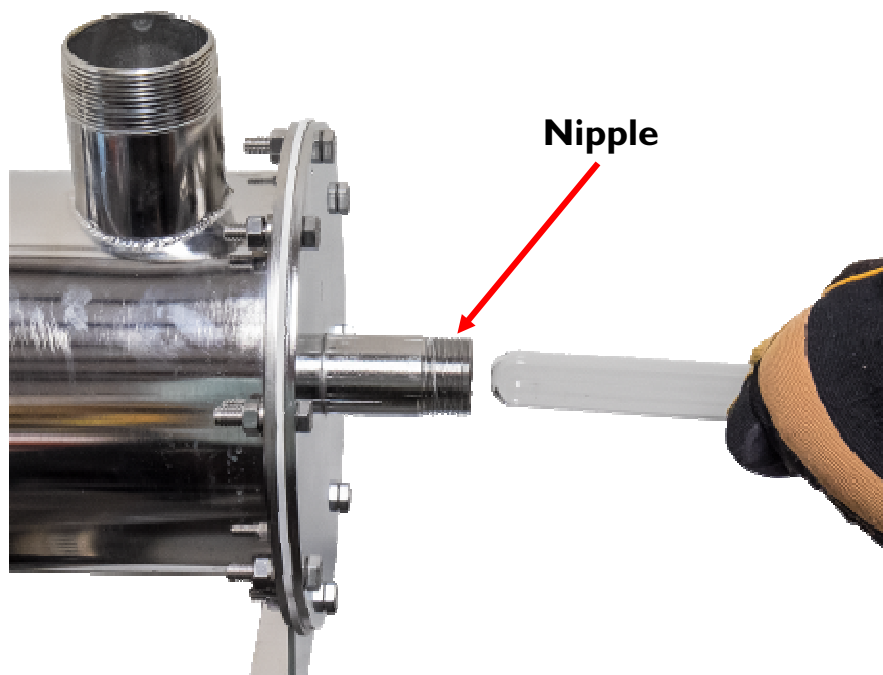
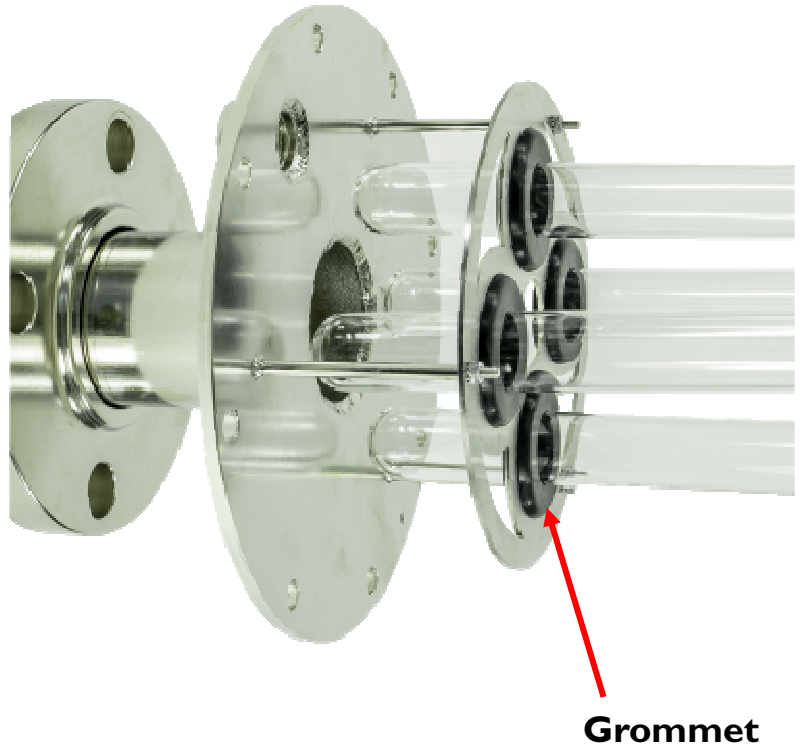

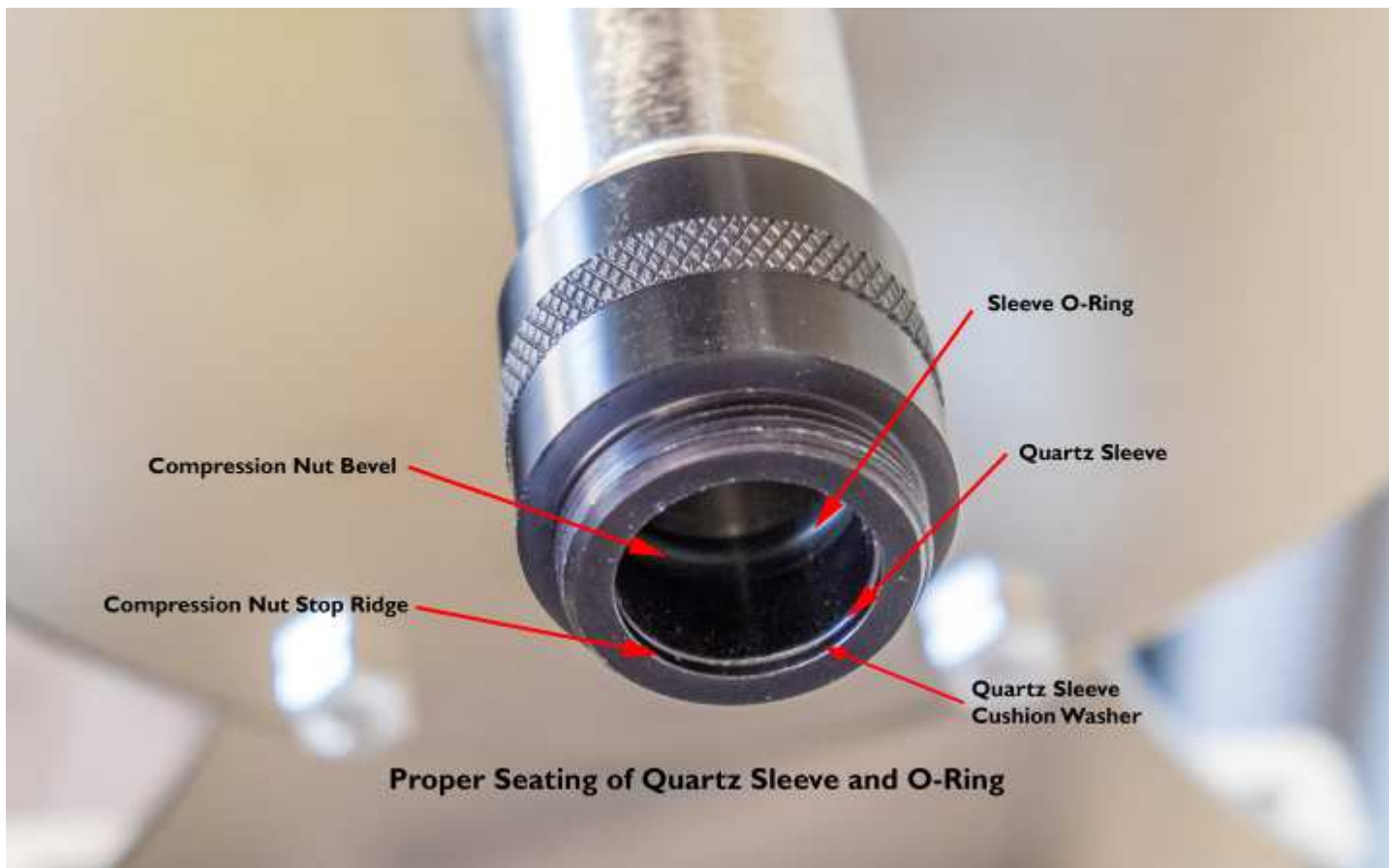

Push the sleeve forward through the corresponding grommet until the compression nut makes contact with the nipple threads. The quartz sleeve should slide freely and have little to no resistance. If this feels tight you may not be sliding the sleeve through the correct grommet. Hand tighten the compression nut until the quartz sleeve makes contact with the stop ridge. Once the compression nut is tightened inspect the nut to make sure the sleeve has been pushed to the stop ridge as in the picture above. The compression fittings should be hand tightened only and the process needs to be completed for each and every quartz sleeve.



Do not use a wrench to tighten the compressions nuts. Doing so can crack the quartz sleeves and cause leakage. **Do NOT install the UV lamp at this time.**

Once secure and once all other ports are closed, it is time to pressurize the system to look for any leaks at the compression seals. Slowly fill the vessel with water. Prevent any onrush of water or water hammer as this may damage the sleeves. Also ensure that the UV lamps have not been placed in the vessel. In the event of a water hammer, the quartz sleeves may break and if the lamps are already installed, they too could break.

Once pressurized, let stand for 10 minutes and inspect the seals. If any are found to be leaking, stop water, release pressure, drain system and then redo the leaking seals. Once redone, run the pressurization test and ensure that all seals are not leaking.



## d) Lamp Installation



Use cloth gloves to handle UV lamps to avoid putting fingerprints on the lamps.

The electrical path for each lamp is identified and carried through the whole electrical system so the LED on the electrical enclosure for lamp one corresponds to lamp one in the UV chamber. Each lamp harness is numbered and each lamp nipple is numbered on the lamp head plate. Match the corresponding numbered lamp lead to the corresponding numbered lamp nipple.



Insert the lamp cushioning spring into the sleeve and slowly slide the lamp into the sleeve, blank end first, pin end last. Leave the lamp protruding out of the sleeve far enough to be able to push the lamp connector onto the lamp. Make sure the lamp connector is firmly pushed onto the lamp base leaving no space between the connector and base. Failure to push the lamp connector all the way onto the base may allow electrical arcing to occur between the pins, overheating the lamp and possibly causing a fire. Feed the lamp into the sleeve and screw on the compression nut cap. Repeat for each lamp. The caps hold the lamp harness in place and prevent exposure to UV radiation.





## 6) Operation and Monitoring

### a) *Electronic Control Center (ECC)*

The ECC will be the focal point for system Operation and Monitoring.

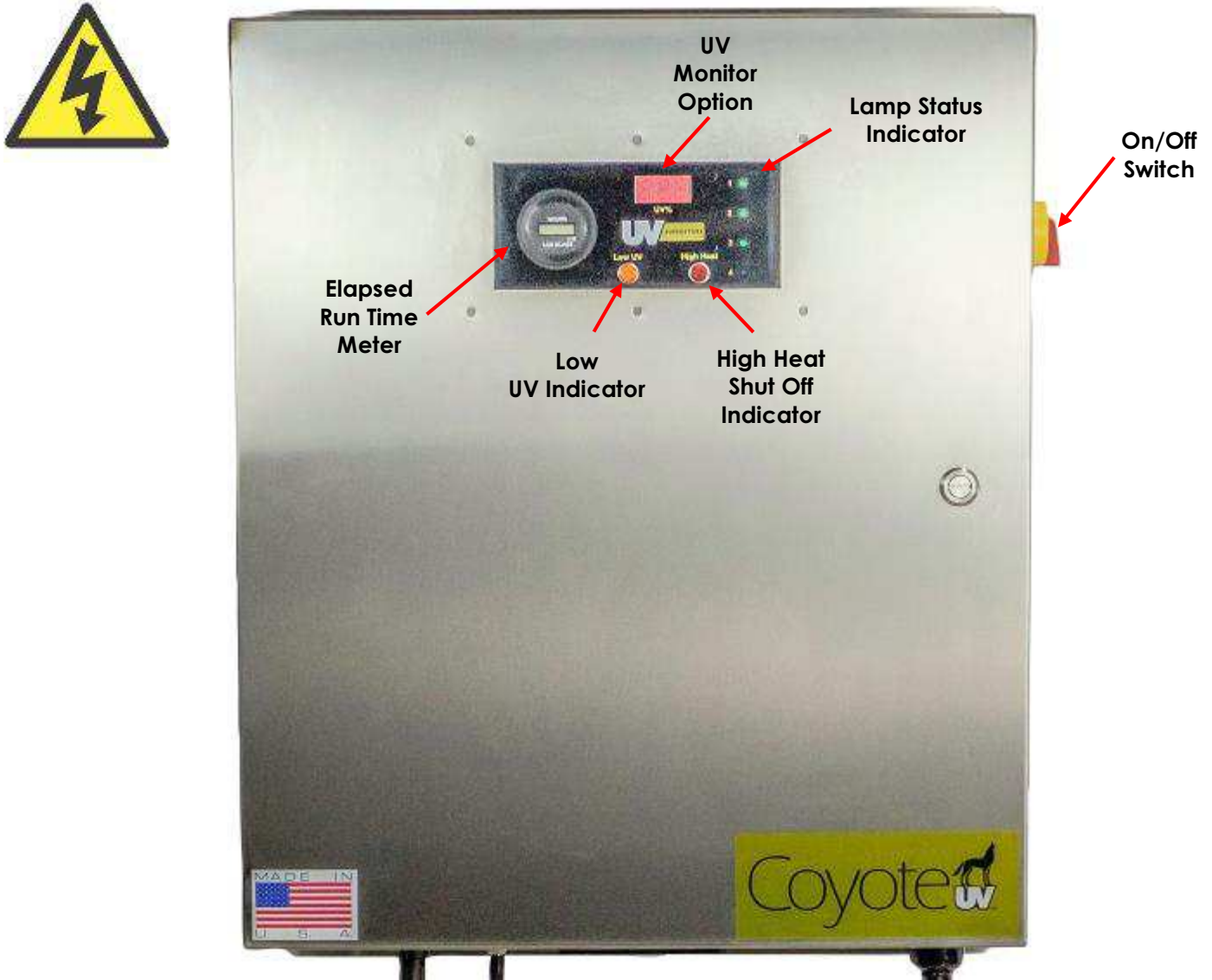

#### **I. Lamp Status**

The ECC will display each individual lamp status indicators in the form of Light Emitting Diodes (LEDs) located on the display plate behind the window on the front door. The LEDs glow green when the lamp is on. An extinguished LED indicates a possible lamp problem.

If the LED goes off, then it may mean that a lamp is no longer functioning. However, it may indicate a problem with the LED, the lamp's corresponding ballast or a problem located within the lamp holder.

## 2. Runtime Monitoring

A digital non-resettable time meter has been integrated into the display plate of the ECC. This elapsed runtime meter (ERTM) tracks operational hours on the system as a whole. It does not track individual lamp run hours nor does it indicate when to service. The runtime meter is a tool to help track running hours to help operators know when it is time to change lamps.

Operators should keep tracking logs in order to know when it is time to change lamps. Lamps need to be changed every 10,000 hours (one year). UV lamps lose intensity over time and the system is designed to provide proper dosage up to 10,000 hours of lamp life. Running the lamps more than 10,000 hours could result in improper UV dosage.

## 3. Viewport

For models not equipped with a UV Monitor, a viewport has been installed on the UV chamber. The purpose of a viewport is to safely verify lamp operation without the potential exposure to UV rays. The viewport assembly consists of a viewport, sight glass, foam washer and an O-ring.

## 4. UV Monitor (Optional)

### Operation

The UV Monitor option consists of a UV sensor probe, a UV Monitor Board, and a UV digital display. UV light output is measured from Lamp #1 at the top of the cylinder by the UV sensor probe, a signal is sent to the UV Meter board for processing, and displayed as a percentage value from 0-100% on the digital display. When new lamps are installed, the board must be calibrated for the new lamps to 100%. As the lamps age and UV intensity falls, the UV display will reflect the lowered UV intensity. When the UV intensity falls below the set trip point, the meter board relay will trip, sounding an audible alarm, illuminating the Low UV lamp on the display, and switching the state on the contact outputs on the board.

### Calibration

The ultraviolet meter can only be calibrated when the power switch is in the ON position and lamps are operational. Lamps must warm up for three minutes prior to any calibrations.

**The board's initial state will be in the fault state.** The Low UV light will be lit and the alarm will sound and the relay will be in the normally open condition. The reason for this state is to allow for lamp warm-up if the unit is equipped with a solenoid valve. If the unit is equipped with a solenoid valve, the lamps will be on, but the coil in the solenoid will be de-energized for three minutes to prevent water flow until the lamps are warmed up and to proper intensity.

**After three minutes, the board will revert to the operational "normal" state.** If the system is at or above minimum intensity, the relay will revert to the normally closed position, the Low UV light will go off, the alarm stop sounding, and if equipped with a solenoid valve, the valve will open and water will flow.

## To calibrate the UV Monitor Board:

### Audible Alarm—

**NOTE:** Many industrial applications do not require an audible alarm for Low UV Intensity. When calibrating the UV Monitor Board, the alarm will sound during the warm-up period. **To disable the alarm,** remove jumper JP13 located at the right edge of the board below the alarm.



**Take caution when removing jumper as exposed prongs may have voltage present!**

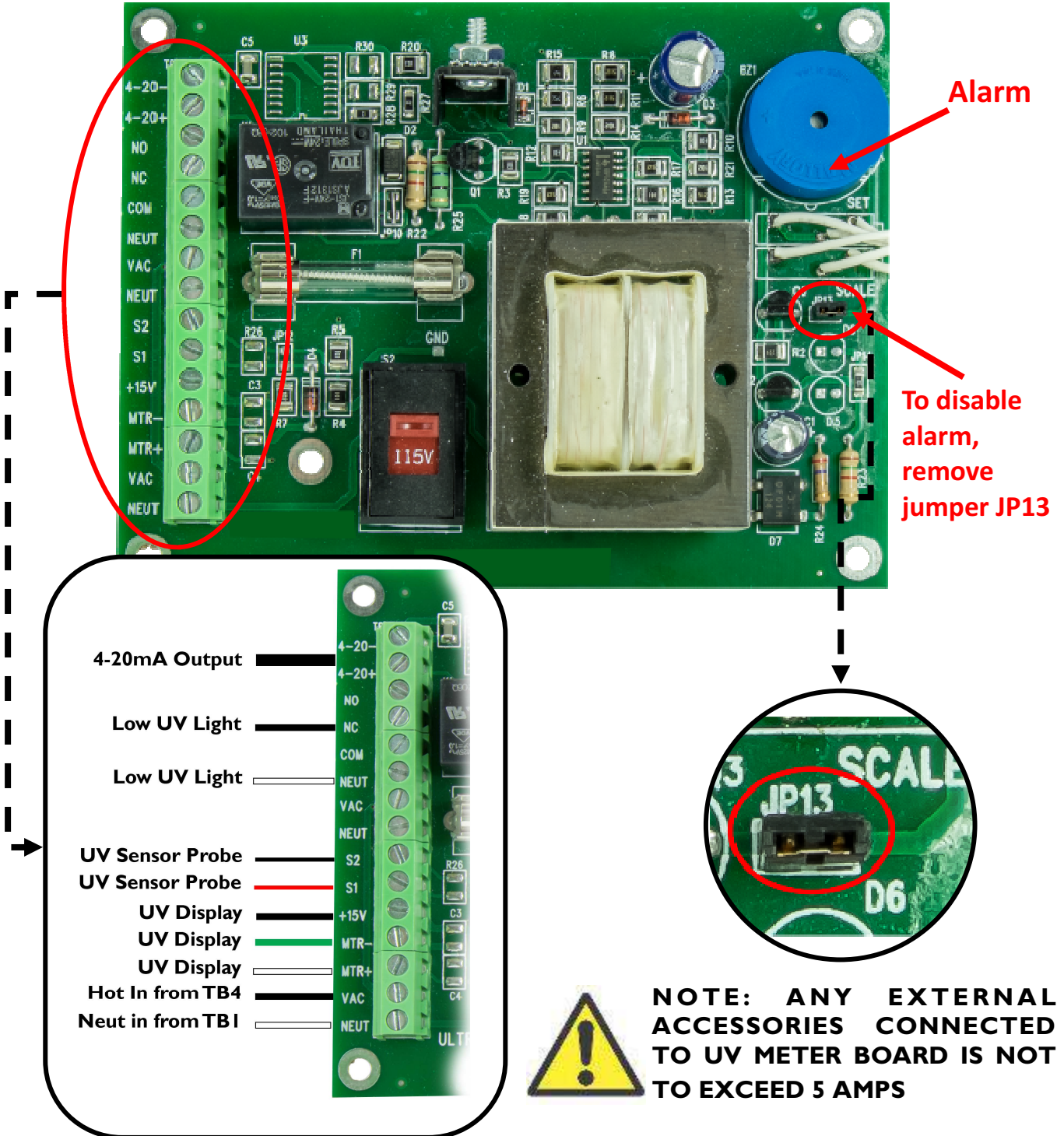

- 1) Calibration must be made with new lamps only.
- 2) Lamps must be allowed to warm up for three minutes prior to any calibrations.
- 3) Open the enclosure door to expose the display plate. On the right side of the display plate, locate the Run potentiometer, the Set potentiometer and the Cal switch.



- 4) First set the trip level. Push and hold the Cal switch and adjust the Set potentiometer until the display reads 85%. When the UV intensity falls below 85% the system will go into the fault state. The UV unit is designed to provide proper UV dosage at 85% of original UV intensity. With modern technology UV lamps, this should occur at about 10,000 hours of continuous use (about one year).
- 5) Release the Cal switch and adjust the Run potentiometer until the display reads 100%.
- 6) When the board is in the normal state, test the calibration by adjusting the Run potentiometer until the display reads below 85% to determine if the low UV lamp lights, indicating the board is functioning properly. Readjust the Run potentiometer until the display reads 100%. (The three minute warm-up period will restart). The UV Meter Board is now calibrated.

## 5. High Heat Sensor (Optional)

### Operation

Optimum operating temperature of a standard Low Pressure ultraviolet lamp is around 105°F. UV intensity falls off when the temperature of the lamp rises above the optimum operating temperature. In order to guard against a possible falloff of UV intensity due to high heat and possible damage to other components, an optional high heat sensor can be used. The High Heat Sensor option consists of a thermostat, a thermostat mounting bracket, a relay, and a High Heat indicator lamp. When an overheat situation occurs, the relay will trip, shutting off power to the ballasts and illuminating the High Heat Lamp indicator.



**Operational “Normal” State** – The High Heat Sensor controls voltage to the High Heat Relay. Voltage flows from the relay’s common terminal to the NO terminal, feeding operating voltage to all components of the ECC allowing “normal” operation of the unit.

**Fault State** – The High Heat Sensor is factory set at 120°F. If vessel temperature reaches 120°F, the thermostat will not allow power to pass through, tripping the High Heat relay. Voltage through the relay will switch from the common terminal to the NC terminal, feeding voltage to the High Heat light and denying voltage to the ballasts and runtime meter. The UV lamps will shut off, the runtime meter will shut off, and the High Heat light will illuminate. If the unit is equipped with an optional UV Monitor, because the lamps are now shut off, the UV monitor will go into the fault state, illuminating the Low UV light, sounding the audible alarm, switching the state of the relay contacts on the UV Meter board, and the UV display should read “0”. The unit will turn back on when water flows, cooling the unit or when water temperature falls below 90°.



## 7) Maintenance

***Always disconnect power before servicing the system.***



### ***a) Lamp Maintenance***

Most ultraviolet lamps are rated to provide 10,000 hours of continuous use. After 10,000 hours, the lamp may no longer provide the sufficient amount of 254nm or 185nm that is required for UV output. Therefore, the lamps need to be replaced on a yearly basis. Lamp status should also be checked on a periodic basis by inspecting the LEDs on the ECC.

It is best to always keep spare lamps available in case of emergency needs.

If it becomes necessary to clean the lamp due to dust or fingerprints, the lamps can be cleaned with denatured alcohol. Use cotton gloves and a clean cloth when cleaning the lamps. Wait for lamps to cool before cleaning.

***b) Quartz Sleeve Maintenance (FRAGILE: Be careful when handling quartz sleeves! Always use cotton gloves when handling.)***

In order to ensure proper disinfection, the quartz sleeves need to be inspected, monitored and maintained. The UV lamps produce heat and UVC output, which may cause certain water characteristics to adhere to and bond on the sleeve preventing the UVC from reaching the targeted pathogens. This can cause the quartz sleeves to foul. To a great extent, your frequency of cleaning will depend upon the water quality (i.e. amount of minerals present in the liquid). The more minerals present in the water, the more frequently the quartz will require cleaning.

### **Manual Cleaning**

Significant film or debris deposits formed on the quartz sleeves will impair the ability of the ultraviolet rays to penetrate through the quartz and into the water.

A periodic visual inspection of the quartz will be necessary to determine the frequency of cleaning. Initial inspection should take place after thirty (30) days of operation. If the quartz are dirty, shorten the cleaning intervals. If the quartz are clean, lengthen the cleaning intervals.

To clean quartz sleeves, depressurize the unit by first turning off the valves on the inlet and then the outlet of the vessel. Turn off the power to the UV system. Drain the vessel. Disconnect the lamps, allow to cool and slowly and carefully remove the lamps using clean cotton gloves. Back off the compression quartz gland nuts and remove the O-rings. The quartz sleeves may be cleaned with denatured alcohol. If this is not adequate, a mild non-abrasive cleaner can be used. It is important to use cleaners that leave no residue. **FRAGILE: Be careful when handling quartz.** Whenever the quartz are cleaned, the quartz O-rings should also be cleaned. Install the quartz sleeves with clean cotton gloves.

It is recommended to replace the quartz sleeve and O-Rings approximately every 3 years. The frequency can vary depending on water conditions.

### **c) Viewport Maintenance**

For models not equipped with a UV Monitor, a viewport has been installed on the UV chamber. The purpose of a viewport is to safely verify lamp operation without the potential exposure to UV rays. The viewport assembly consists of a viewport, sight glass, foam washer and an O-ring.

The foam washer acts as a cushion between one side of the sight glass and the viewport itself. The O-ring provides a seal and serves as a cushion to the other side of the sight glass.

This assembly will require periodic maintenance similar to the lamp and quartz maintenance schedule. A periodic visual inspection of the viewport assembly is recommended. Unscrew the nickel plated viewport from the chamber and inspect the sight glass for any cracks. If a crack has occurred this will need to be replaced. It is recommended to replace the O-ring every 3-5 years as the O-ring can degrade over time.

Reattach viewport after routine maintenance has been performed.

### **d) Sensor Probe Maintenance**

For models equipped with a UV Monitor, a sensor probe has been installed on the UV chamber. The sensor probe contains an O-ring that will need to be replaced periodically. Annual routine maintenance is recommended similar to lamp and quartz maintenance.

Unscrew the sensor probe from the sensor port. Inspect and clean as needed. A buildup can coat the sensor probe and failure to clean may result in a false reading. It is recommended to replace the O-ring every 3-5 years as the O-ring can degrade over time.

Reattach sensor probe after routine maintenance has been performed.

### **e) ECC Maintenance**



The Electronic Control Enclosure (ECC) is custom designed with a sealed door and sealed Lexan window kit. It should require little maintenance other than occasional cleaning. A damp cloth and mild detergent can be used to clean the outside of the enclosure. While most penetrations are sealed, it is not suitable to withstand a hose wash-down or large amounts of water. Any water penetrating the enclosure can lead to damage and possible electrical shock.

### **f) Chamber Maintenance**



The chamber requires periodic maintenance. The Chamber is made of 316L stainless steel and is electropolished and passivated. It should provide years of reliable service. The exterior can be cleaned with a damp cloth and mild detergent or a stainless steel cleaner. **Be careful around the compression nuts as the compression cap is not watertight.** The chamber interior will require cleaning on a periodic basis depending on the quality of the water passing through. Some water will introduce solids, minerals, and other debris in the vessel. Inspection of the vessel can be made without removal of the heads.

Prior to performing inspection, ensure that the power to the ECC and that the water supply has been turned off before and after the chamber. Once isolated, drain the system. Prior to draining, release pressure in line by opening a valve. Failure to do these tasks can result in serious injury and property damage.

Once drained, the operator can remove a lamp and quartz sleeve to peek through a nipple in the lamp head to get a limited view of the vessel. The UV sensor probe (if so equipped), or the viewport can also be removed to inspect the chamber.

The heads can also be removed to inspect or clean the chamber.

## **Chamber Breakdown – Removal of Heads**



Once determined that the vessel needs to be cleaned, the operators will need to set aside some work time to perform a complete system breakdown.

As with inspection, the vessel needs to be powered off, completely drained and allowed to cool down.

The operators will need to remove the lamps, the compression nuts, O-rings and quartz sleeves. All of these parts should be checked for wear and should be stored in an area where they will not get lost or broken.

Operators will need to loosen the nuts and bolts on the lamp head plate and inlet head plate. Once loosened, the nuts, bolts and lock washers need to be removed and stored.

The head will need to be replaced in the exact position in which it was removed. There is an alignment pin on the cylinder flange that mates to a hole in the removable head to ensure the head is in the proper position upon reinstallation.



Lower the head to the ground. The gasket should be inspected for wear and also stored in a safe place. Having one head off will allow for both visual inspection and cleaning.

Once cleaned, perform maintenance on the quartz sleeves and replace any gaskets/O-rings. **NOTE: It is recommended that a new gasket be installed.**

When re-installing the head, use a crisscross pattern to tighten the nuts. This is similar to putting a tire on a car. Bolts should be torqued to 25 foot pounds.



### ***g) High Heat Shutoff Maintenance—***

Many applications can have significant times of no flow. During these times, heat can build up in the vessel. To prevent the lamps from overheating and the quartz sleeve fouling, a thermostat (high heat shut off) may have been provided as an option.

The High Heat Sensor is attached to the cylinder flange plate welded to the vessel. It is held in place with a mounting bracket held by one of the head plate bolts. The sensor is attached to the electronics via a plug in connector. The sensor generally shuts down at 120°F. This is meant to protect the lamps. The system will turn back on once the system cools down. The sensor is factory set and cannot be adjusted. No maintenance is needed other than to make sure the sensor is held tightly in place.

## **8) Water Sampling (for Flange Models) —**

UV Superstore, Inc. recommends a program of water sampling to ensure delivery of the desired water quality. While the frequency of sampling will depend upon site conditions and requirements, the user should establish a disciplined program.

### **a) Sampling Valves**

UV Superstore, Inc. recommends installation of sampling valves on the inlet and outlet sample ports located on the ultraviolet unit risers. The wetted material should be 316 stainless steel construction. A minimal length of thread connections of the sample valve port should be maintained to reduce the dead volume on the upstream side of the valve. The inside diameter of the sample valve must not exceed one-quarter inch (1/4") to insure proper velocity. Any valve used for sampling should be constructed in a manner to reduce or prevent the retention of bacteria within its internal surfaces. The valve should also be easy to sanitize.

### **b) Sampling Procedure**

- 1) Prior to sampling the water, acquire an adequate supply of bacteriological monitors, total count water samplers, pre-sterilized plastic bottles within pre-sterilized plastic bags from a water testing laboratory.
- 2) With the ultraviolet system operating, open the sample valve fully and flush for at least one minute at full fast flow. Then, close the valve.
- 3) Sanitize the valve and sampling port in accordance with the proper standards established for the specific valve installed. Isopropyl alcohol 70% to 90% is recommended.
- 4) Fully open and flush the valve again to remove any contaminants. The flushing time sequence may run from a minimum of three to five minutes. Do not reduce the water flow before taking the water sample because the back of the valve (not previously exposed) may contain contaminants. If you reduce the flow prior to taking a sample, continue to flush as before.
- 5) When sampling, take the measurement at the center of the stream in order to reduce the possibility of bio-fouling.
- 6) Follow ASTM or your bacteriological monitor manufacturer guidelines when using that monitor, with a total count water sampler and a pre-sterilized plastic bag, to sample the in-line.
- 7) Carefully fill the pre-sterilized bottle from the bottom up allowing the water stream to overflow and flush the bottle for a minimum of one minute.

## CoyoteUV® Amalgam Series General System Specifications

| Model #                                 | CY2-A                     | CY2-A-TOC<br>CY2-A-O3D                           | CY3-A                     | CY3-A-TOC<br>CY3-A-O3D                           | CY4-A  | CY4-A-TOC<br>CY4-A-O3D                           |
|---|---------------------------|--|---------------------------|--|--|--|
| Max Capacity Clear Fresh Water          | 110 GPM                   |  | 200 GPM                   |  | For sizing parameters consult Sales team         |  |
| Max Capacity DI/RO Water Disinfection   | 125 GPM                   | For sizing parameters consult Sales team         | 235 GPM                   | For sizing parameters consult Sales team         | For sizing parameters consult Sales team         | For sizing parameters consult Sales team         |
| UV Dosage Millijoule/cm <sup>2</sup>    | 30 mJ/cm <sup>2</sup>     | Dosage parameters vary depending on requirements | 30 mJ/cm <sup>2</sup>     | Dosage parameters vary depending on requirements | Dosage parameters vary depending on requirements | Dosage parameters vary depending on requirements |
| Inlet/Outlet Connection                 | 3" Flange<br>3" Sanitary  | 3" Flange<br>3" Sanitary                         | 3" Flange<br>3" Sanitary  | 3" Flange<br>3" Sanitary                         | 3" Flange<br>3" Sanitary                         | 3" Flange<br>3" Sanitary                         |
| No of UV Lamps                          | 2                         | 2  | 3                         | 3  | 4  | 4  |
| Lamp Watts (Total)                      | 240 W                     | 240 W  | 360 W                     | 360 W  | 480 W  | 480 W  |
| Voltage                                 | 120V<br>50-60Hz           | 120V<br>50-60Hz                                  | 120V<br>50-60Hz           | 120V<br>50-60Hz                                  | 120V<br>50-60Hz                                  | 120V<br>50-60Hz                                  |
| Electrical Enclosure LxWxH: Inches (cm) | 22 x 29 x 7<br>(56x74x18) | 22 x 29 x 7<br>(56x74x18)                        | 22 x 29 x 7<br>(56x74x18) | 22 x 29 x 7<br>(56x74x18)                        | 22 x 29 x 7<br>(56x74x18)                        | 22 x 29 x 7<br>(56x74x18)                        |
| Electrical Enclosure Material           | 304 SS                    | 304 SS   | 304 SS                    | 304 SS   | 304 SS   | 304 SS   |
| Treatment Chamber Material              | 316L SS                   | 316L SS  | 316L SS                   | 316L SS  | 316L SS  | 316L SS  |
| Standard Operating Pressure             | 150 PSI                   | 150 PSI  | 150 PSI                   | 150 PSI  | 150 PSI  | 150 PSI  |
| <b>Options</b>                          |                           |  |                           |  |  |  |
| UV Monitor                              | Yes                       | Yes  | Yes                       | Yes  | Yes  | Yes  |
| UV Monitor w/ 4-20mA Output             | Yes                       | Yes  | Yes                       | Yes  | Yes  | Yes  |
| High Heat Shutoff                       | Yes                       | Yes  | Yes                       | Yes  | Yes  | Yes  |
| Voltage                                 | 220V/240V<br>50-60Hz      | 220V/240V<br>50-60Hz                             | 220V/240V<br>50-60Hz      | 220V/240V<br>50-60Hz                             | 220V/240V<br>50-60Hz                             | 220V/240V<br>50-60Hz                             |

## Parts Breakdown—Coyote Amalgam Series

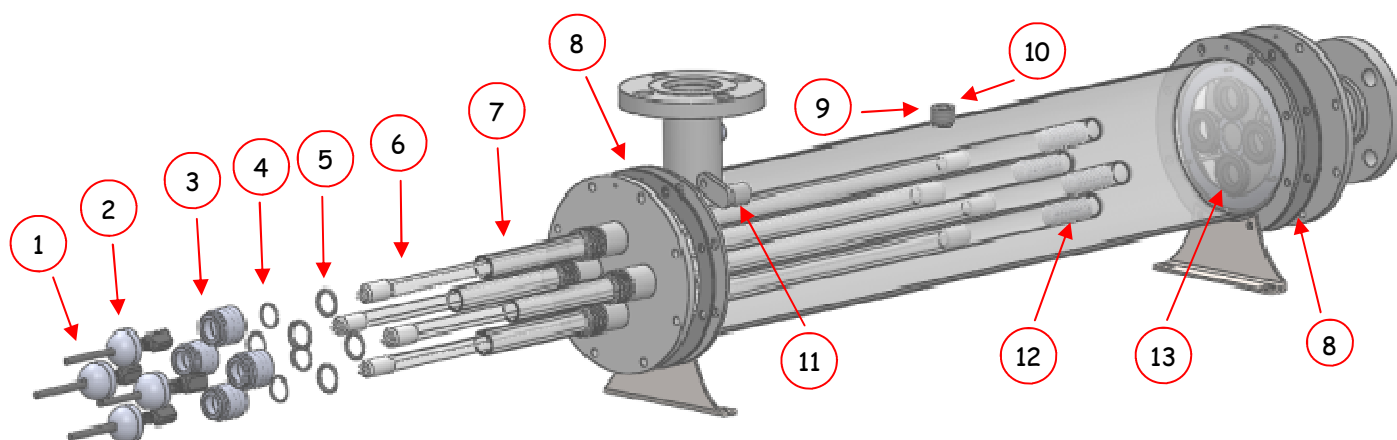

| Item No. | Part No.      | Description   | Quantity required |       |       |
|----------|---------------|---|-------------------|-------|-------|
|          |               |   | Model No.         |       |       |
|          |               |   | CY2-A             | CY3-A | CY4-A |
| 1        | LH0002        | Lamp Harness  | 2                 | 3     | 4     |
| 2        | CN0002        | Compression Cap   | 2                 | 3     | 4     |
| 3        | CN0001        | Compression Nut   | 2                 | 3     | 4     |
| 4        | 4255          | Sleeve Cushion O-Ring   | 2                 | 3     | 4     |
| 5        | ORNG0009      | Sleeve O-Ring, EPDM   | 2                 | 3     | 4     |
| 6        | GL-5843-4A74G | Lamp—254NM  | 2                 | 3     | 4     |
|          | GV-5843-4A74B | Lamp—185NM  | 2                 | 3     | 4     |
| 7        | G36-2450      | Quartz Sleeve, Domed  | 2                 | 3     | 4     |
| 8        | GSKT0001      | Head Gasket   | 2                 | 2     | 2     |
| 9        | VPM0001       | UV Viewport   | 1                 | 1     | 1     |
|          | 002045        | O-Ring for UV Viewport<br>(For Models without UV Monitor)     | 1                 | 1     | 1     |
| 10       | 4-0008        | UV Sensor Probe   | 1                 | 1     | 1     |
|          | ORNG0018      | O-Ring for UV Sensor<br>(For Models with Optional UV Monitor) | 1                 | 1     | 1     |
| 11       | THERM0100     | Thermistor<br>(For Models with Optional High Heat)            | 1                 | 1     | 1     |
| 12       | SPRING0001    | Spring  | 2                 | 3     | 4     |
| 13       | GRMT0001      | Grommet   | 2                 | 3     | 4     |

## Electrical Enclosure Replacement Parts List

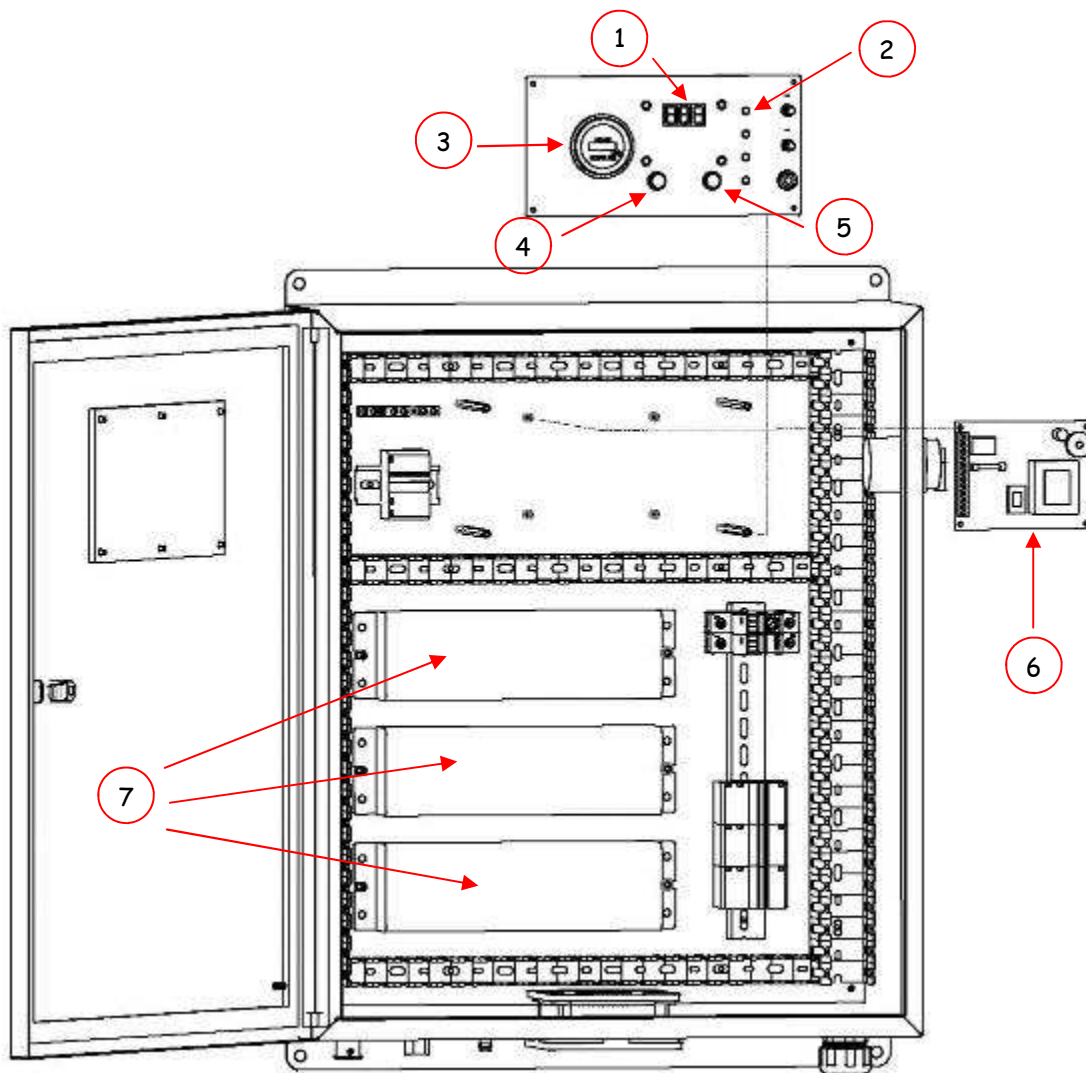

| Item No. | Part No.     | Description  | Quantity required |       |       |
|----------|--------------|--|-------------------|-------|-------|
|          |              |  | CY2-A             | CY3-A | CY4-A |
| 1        | ELEN0028     | Intensity Display Board<br>(For Models with Optional UV Monitor)           | 1                 | 1     | 1     |
| 2        | LED0006      | Lamp Status Indicator  | 2                 | 3     | 4     |
| 3        | ERTM0100     | Elapsed Runtime Meter  | 1                 | 1     | 1     |
| 4        | LGHT0003     | Low UV Indicator—120V  | 1                 | 1     | 1     |
|          | LGHT0004     | Low UV Indicator—220V  | 1                 | 1     | 1     |
| 5        | LGHT0001     | High Heat Shutoff Indicator—120V   | 1                 | 1     | 1     |
|          | LGHT0002     | High Heat Shutoff Indicator—220V   | 1                 | 1     | 1     |
| 6        | ELEN0029     | UV Meter Board   | 1                 | 1     | 1     |
|          | ELEN0029-420 | UV Meter Board with 4-20mA Output<br>(For Models with Optional UV Monitor) | 1                 | 1     | 1     |
| 7        | BLST0015     | Ballast 120V 50-60Hz   | 2                 | 3     | 4     |
|          | BLST0016     | Ballast 230V 50-60Hz   | 2                 | 3     | 4     |

# ***Food and Drug Administration Statement***

UV Superstore provides state of the art Ultraviolet Water and Air Treatment Systems for many commercial and industrial applications.

The U.S Food and Drug Administration approval process does not allow for individually approval of any material, piece of equipment, or apparatus that is not deemed a medical device. Therefore UV Superstore designs our brand UV Systems and spare parts to be in compliance with the U.S Food and Drug Administration Code Of Federal Regulations Title 21 Sub Section 177.

Stainless Steel and quartz material are acceptable in FDA applications. All O-ring and gasket materials are in compliance with Title 21 Sub Section 177.

The U.S Food and Drug Administration regulations that deal with the items addressed above are as follows:

- 1) Part 129, Subpart C, Sec. 129.40 Equipment and procedures.
- 2) Part 177, Subpart C, Sec. 177.2600 Rubber articles intended for repeated use.
- 3) Part 211, Subpart D, Sec 211.65 Equipment Construction.

All UV Superstore products are built to exacting standards with the highest quality materials available to meet the above referenced guidelines.

UV Superstore, Inc.  
Engineering Department

# CoyoteUV<sup>®</sup> Amalgam Series Ultraviolet Treatment Systems

## Heat Sanitization

For Heat Sanitization we suggest no higher than 194°F and if the unit has a UV Monitor, the sensor probe must be removed and that port capped off prior to sanitization. The UV sensor probe port is a garden hose thread. A garden hose cap and hose washer is available at any hardware or home improvement store.

The most critical part is that the system is not heated or cooled to quickly, as with anything made with like materials if this is heated or cooled to quickly there is a good chance of very fast expansion or contraction and this is where the problems will come from as far as cracking of the SS chamber or welds, compression fittings failure, quartz sleeves failure and other components failure along with chances of leaking by the various seals for the UV system. Heat and cool SLOWLY.

- Turn UV System OFF, UV Lamps should not be operational during this process.
- Maximum Temperature: 194 Degrees F.
- Remove UV Sensor Probe and cap this port.
- Heat and cool SLOWLY to avoid fast expansion or contraction.





**Model Number**

---

**Serial Number**

---

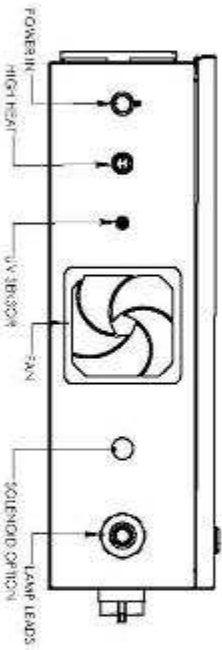
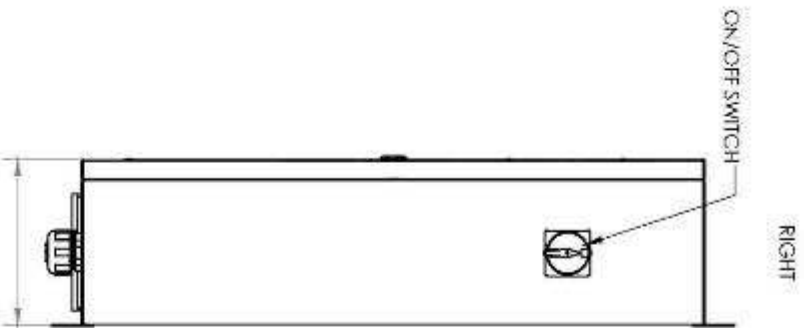
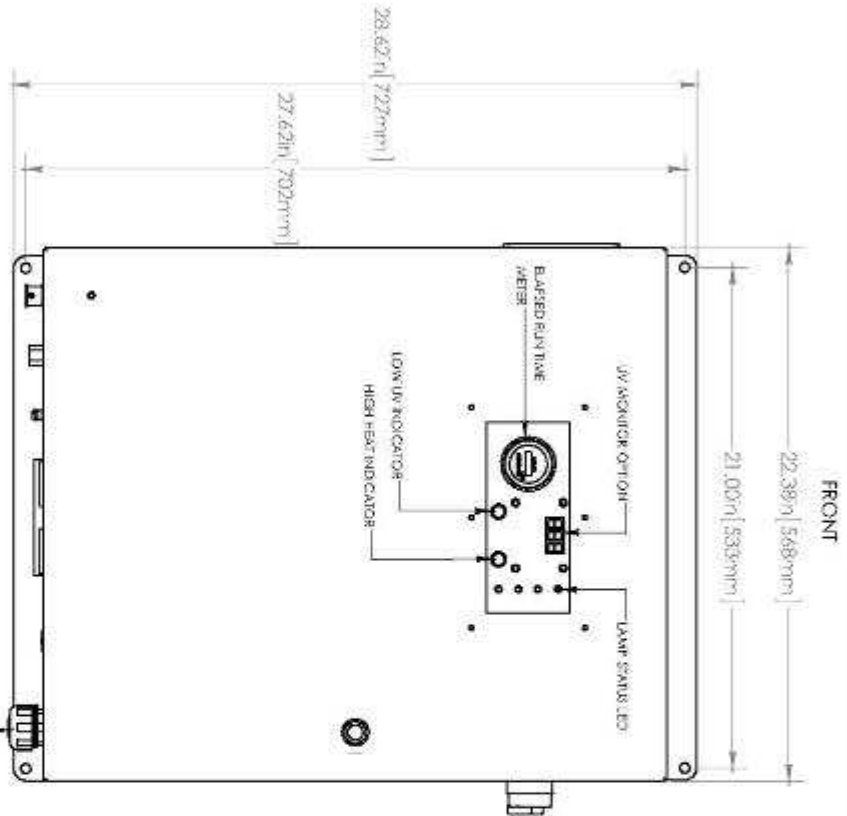
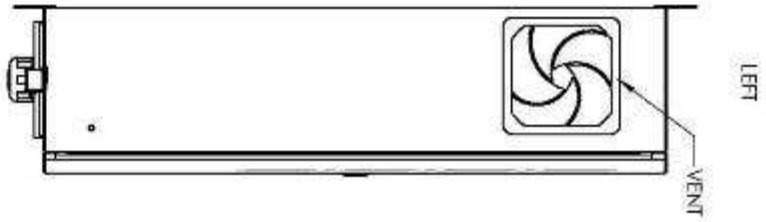

**UV**  
Irradiation

UV Spectroline, Inc.  
850 Tucker Ct.  
Winnetka, CA 94086  
P: 770.397.8800 F: 770.397.8872  
www.uvmonitor.com

THE  
OOVITE AMALGAM HIGH HEAT UV MONITOR

MATERIAL: 304 STAINLESS STEEL

INDICATIONS CONTAINED HEREIN ARE FOR INFORMATION ONLY AND DO NOT CONSTITUTE AN OFFER OR A CONTRACT. THE USER SHALL BE RESPONSIBLE FOR OBTAINING ALL NECESSARY PERMITS AND REGULATIONS FOR INSTALLATION AND USE.

|          |         |              |
|----------|---------|--------------|
| 12-215   | BY: BC  | SHEET 1 OF 1 |
| DWG. NO. | ME-CYAX | REV          |

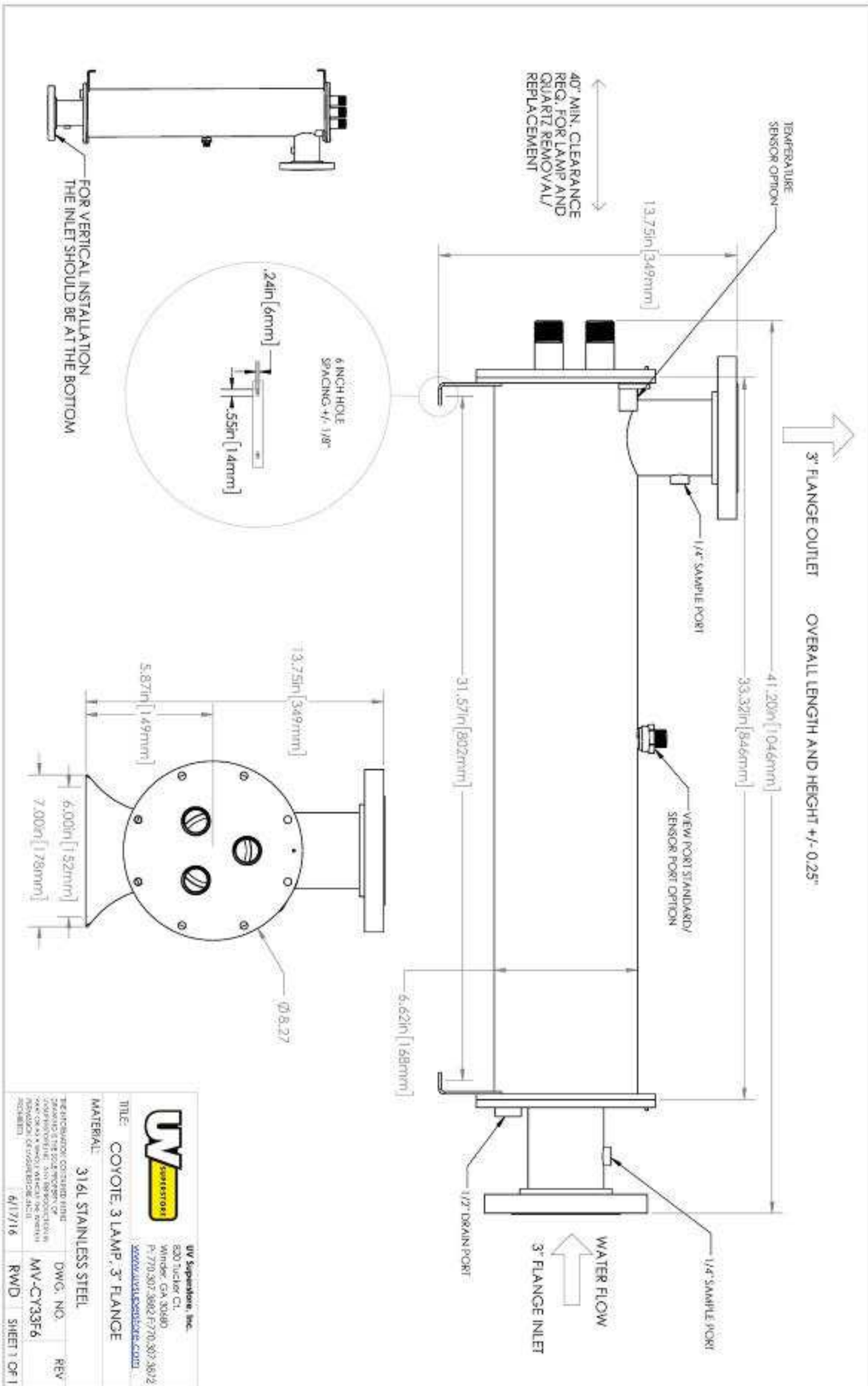

## Troubleshooting

| Situation  | Recommended Action  |
|--|---|
| Lamp status LED light is out                           | <ul style="list-style-type: none"> <li>• Check lamp socket and lamp connection. Verify it is securely connected.</li> <li>• If lamp is on, replace LED assembly.</li> <li>• If lamp is out, go to next step “lamp is out”.</li> </ul>   |
| Lamp is Out  | <ul style="list-style-type: none"> <li>• Exchange lamp connectors from questionable lamp to known good lamp. If lamp lights, replace bad lamp.</li> <li>• If the lamp does not light, exchange lamp connectors at enclosure from questionable ballast to known good ballast. If lamp lights, replace ballast.</li> <li>• Check input voltage. Must be above 120V/60Hz or 220V/50Hz. Install a voltage regulator or check for floating neutral at power source.</li> </ul> |
| Short Lamp Life  | <ul style="list-style-type: none"> <li>• Damper excessive vibration which causes degradation of lamp filaments by checking for poorly connected pipes, erratic or improperly installed pumps, or move the UV equipment to isolate it from vibration.</li> <li>• Consult manufacturer for frequent start/stop requirements (recommend not more than six (6) in 24-hour period).</li> </ul>   |
| Leak at Quartz End Plate                               | <ul style="list-style-type: none"> <li>• Inspect the compression nut and O-ring to ensure the nut is tightened and O-ring is sealed properly.</li> <li>• Inspect quartz sleeve. Ensure the quartz sleeve is not cracked. Replace if defective or cracked.</li> <li>• O-rings and gaskets can deteriorate and become damaged over time. Replace O-ring and/or gasket.</li> <li>• When replacing end gasket, make sure bolts are torqued to 25 foot lbs.</li> </ul>         |
| Poor Bacterial Performance                             | <ul style="list-style-type: none"> <li>• Replace old or defective lamps.</li> <li>• Inspect quartz sleeve(s) and make sure it is clean.</li> <li>• Check water quality. Ensure that color, turbidity, and iron content are within normal parameters.</li> <li>• Verify sampling technique.</li> <li>• Verify flow rate.</li> <li>• Ensure proper sample valves are used.</li> <li>• Check for bypass valve contamination.</li> </ul>                                      |
| Low UV Monitor Reading<br>(Less than 85% transmission) | <ul style="list-style-type: none"> <li>• Check water quality. Ensure that color, turbidity, and iron content are within normal parameters.</li> <li>• Verify lamp output.</li> <li>• Ensure input voltage matches requirements.</li> <li>• Replace old or defective lamp(s).</li> <li>• Clean quartz sleeve(s).</li> <li>• Clean UV sensor lens.</li> <li>• If reading is at 0%, ensure UV sensor cable is connected.</li> </ul>  |

If questions still remain after completing a troubleshooting procedure, please contact the manufacturer.

## Limited Warranty

UV Superstore's CoyoteUV® Commercial/Industrial Water Treatment systems are provided with a limited warranty. These units carry a warranty to be free from defects in materials and workmanship for one year from date of purchase under the conditions of normal usage and service for the complete system. Additionally, these units carry a four year warranty for the treatment chamber and a two year warranty for the electronic power supply. If the product fails or malfunctions during the warranty period, UV Superstore shall inspect the inoperative product and have the option to repair or replace any components, which, in the assessment of UV Superstore were originally defective or became so under normal conditions of use and service. Customers must first call UV Superstore and be issued a Return Authorization number before returning any product or component. The equipment or component must be returned to UV Superstore freight prepaid and insured to the address below.

## Warranty Statement

UV Superstore warrants replacement lamps, purchased for routine maintenance, to be free from defects in material and workmanship for a period one year from the date of purchase. During this time, UV Superstore will repair or replace, at its option, a defective lamp free of charge except for shipping and handling charges and any prorated charges (where applicable).

The warranty period on replacement lamps will be verified using date codes and/or purchase receipts. UV Superstore will advise whether the defective item needs to be returned for failure analysis.

None of the above warranties cover damage caused by improper use or maintenance, accidents, acts of God or minor scratches or imperfections that do not materially impair the operation of the lamp. The warranties also do not cover products that are not installed as outlined in the applicable Owner's Manual.

The limited warranties described above are the only warranties applicable to the equipment outlined. These limited warranties outline the exclusive remedy for all claims based on a failure of or defect in any of these lamps, whether the claim is based on contract, tort (including negligence), strict liability or otherwise. These warranties are in lieu of all other warranties whether written, oral, implied or statutory. Without limitation, no warranty of merchantability or of fitness for a particular purpose shall apply to any of this equipment.

UV Superstore, Inc. does not assume any liability for personal injury or property damage caused by the use or misuse of any of the above products. UV Superstore, Inc. shall not in any event be liable for special, incidental, indirect or consequential damages. UV Superstore liability shall, in all instances, be limited to repair or replacement of the defective product or part and this liability will terminate upon expiration of the applicable warranty period.

For all warranty claims you must contact UV Superstore at the below address. All claims must be filed within 30 days.



820 Tucker Court, Winder, GA 30680

Phone: 770-307-3882

Fax: 770-307-3872

[sales@uvsuperstore.com](mailto:sales@uvsuperstore.com)

[www.uvsuperstore.com](http://www.uvsuperstore.com)







820 Tucker Court, Winder, GA 30680

**Phone: 770-307-3882**

**Fax: 770-307-3872**

[sales@uvsuperstore.com](mailto:sales@uvsuperstore.com)

[www.uvsuperstore.com](http://www.uvsuperstore.com)