



Amalgam Models

Four Lamp Systems – Short Design
Mechanical Drawings

3" Flange

3" Sanitary

Enclosure

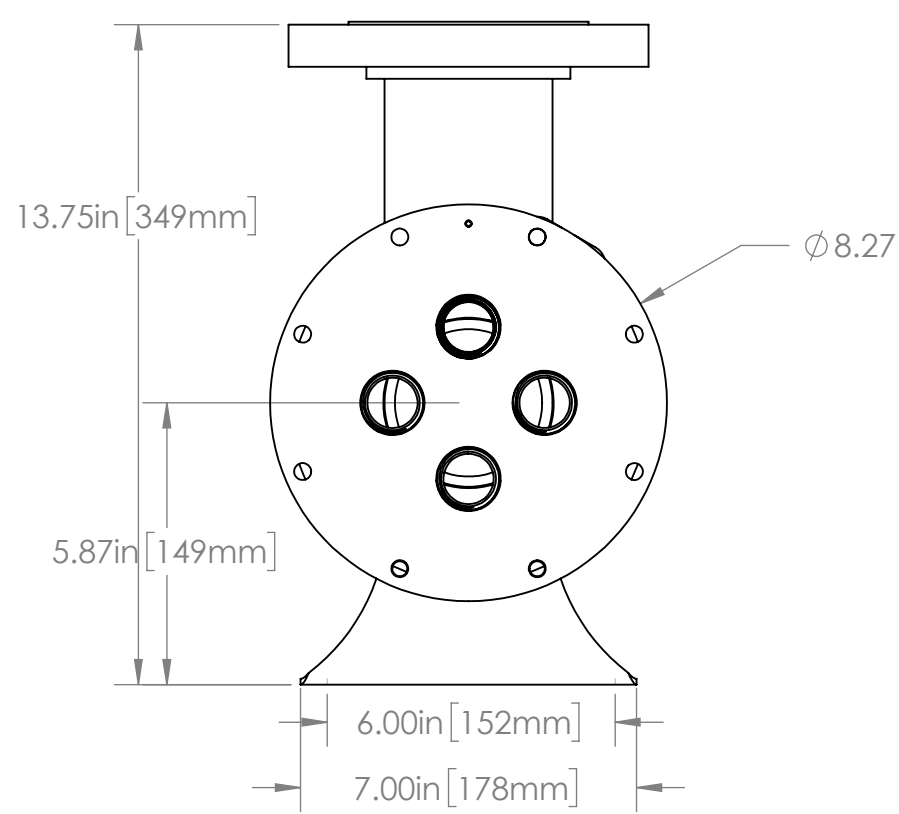
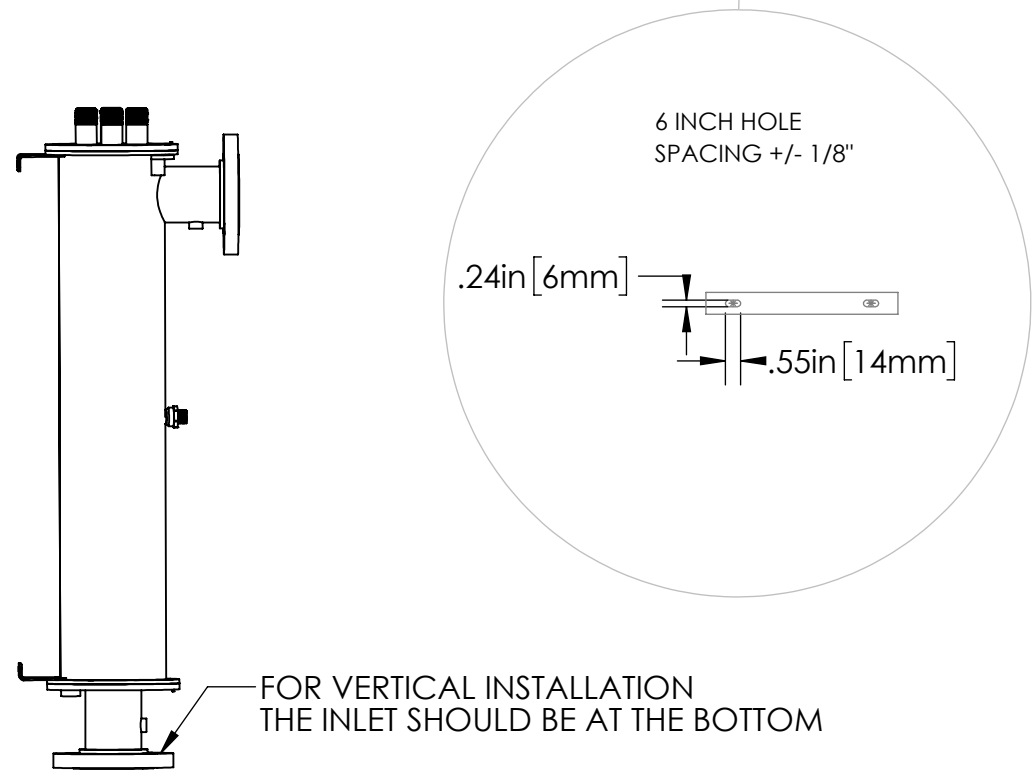
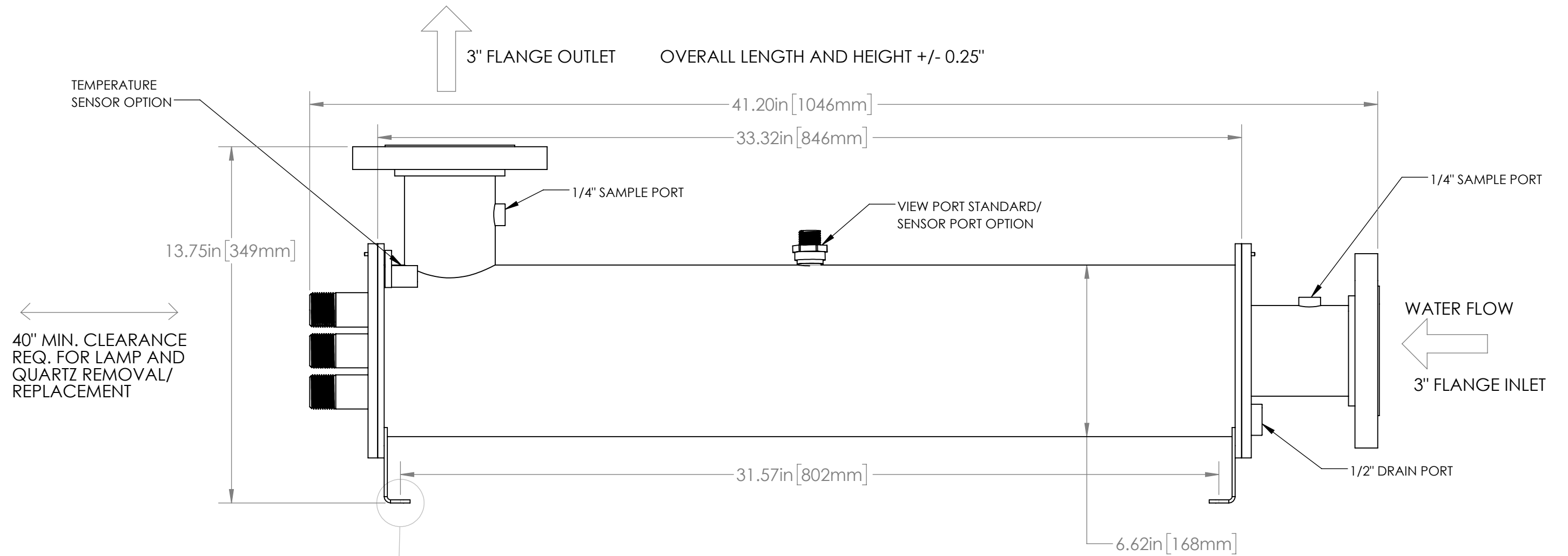

UV SUPERSTORE

UV Superstore, Inc.
820 Tucker Ct.
Winder, GA 30680
P: 770.307.3882 F:770.307.3872
www.uvsuperstore.com

TITLE: COYOTE, 4 LAMP, 3" FLANGE

MATERIAL: 316L STAINLESS STEEL

THE INFORMATION CONTAINED IN THIS DRAWING IS THE SOLE PROPERTY OF UVSUPERSTORE, INC. ANY REPRODUCTION IN PART OR AS A WHOLE WITHOUT THE WRITTEN PERMISSION OF UVSUPERSTORE, INC IS PROHIBITED.

DWG. NO.	REV
MV-CY43F6	
6/17/16	RWD
	SHEET 1 OF 1

3" SANITARY OUTLET

OVERALL LENGTH AND HEIGHT +/- 0.25"

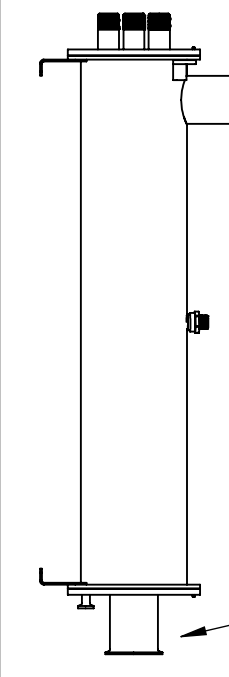
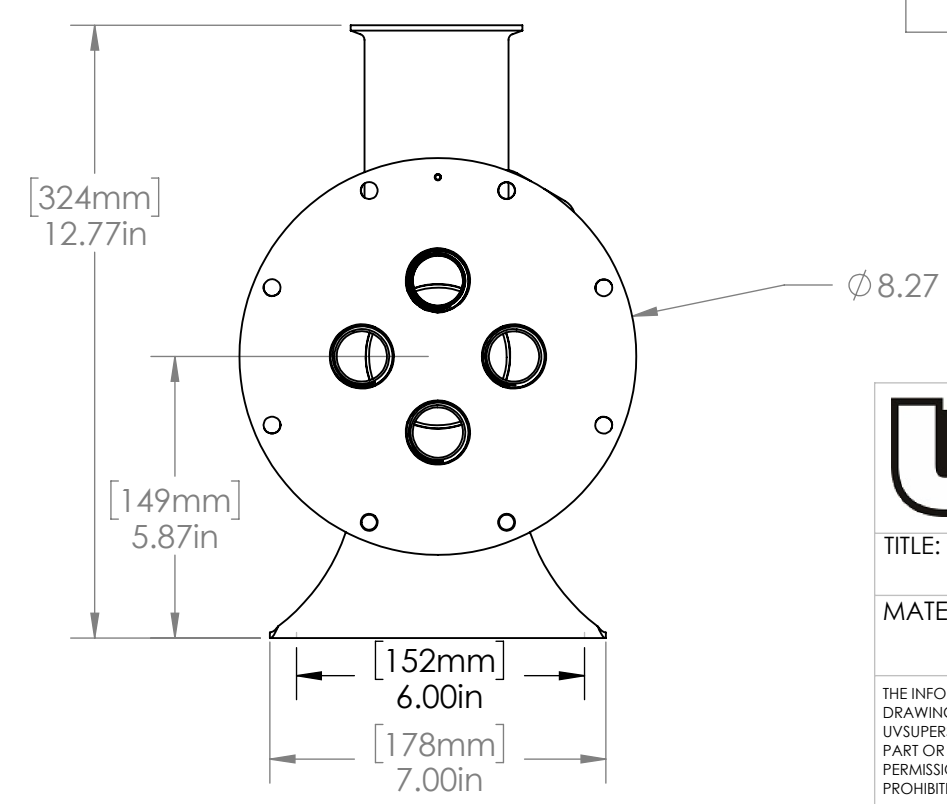
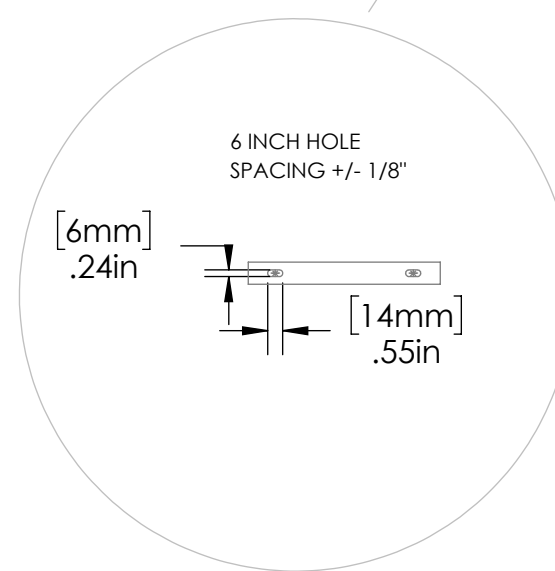
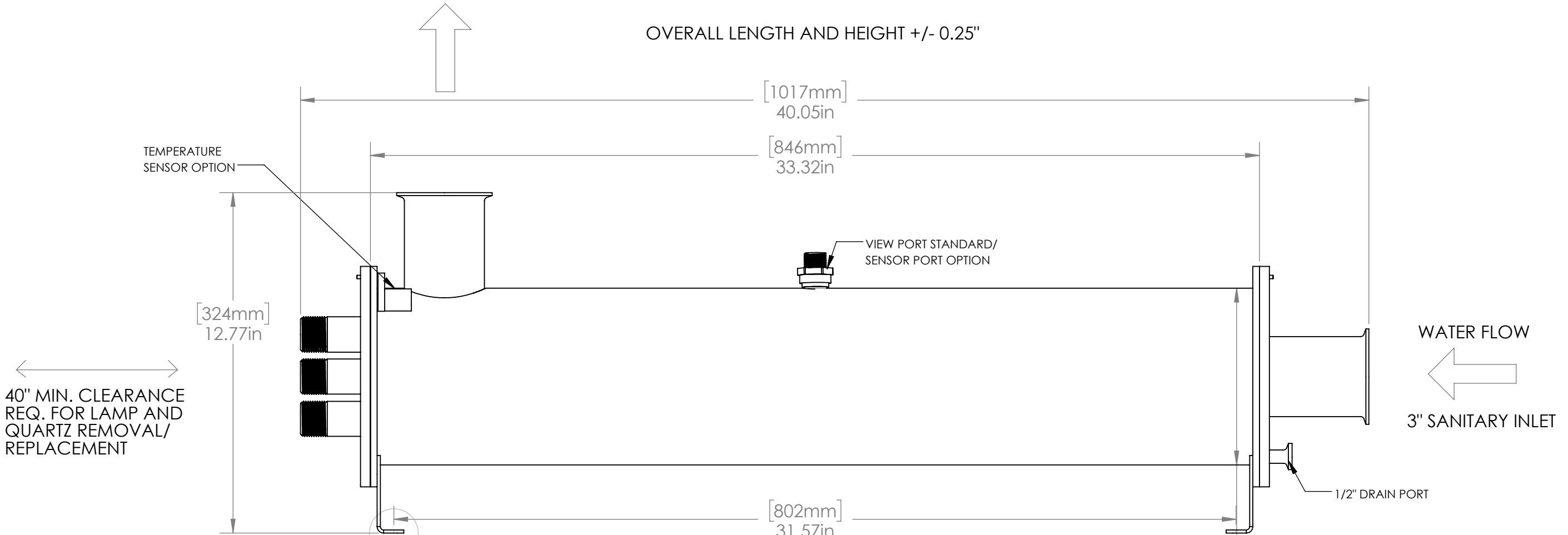

	UV Superstore, Inc. 820 Tucker Ct. Winder, GA 30680 P: 770.307.3882 F:770.307.3872 www.uvsuperstore.com	
	TITLE: COYOTE, 4 LAMP, 3" SANITARY	
MATERIAL: 316L STAINLESS STEEL		DWG. NO. MV-CY43S6
<small>THE INFORMATION CONTAINED IN THIS DRAWING IS THE SOLE PROPERTY OF UVSUPERSTORE, INC. ANY REPRODUCTION IN PART OR AS A WHOLE WITHOUT THE WRITTEN PERMISSION OF UVSUPERSTORE, INC IS PROHIBITED.</small>		REV 3/10/16 BY: RWD SHEET 1 OF 1

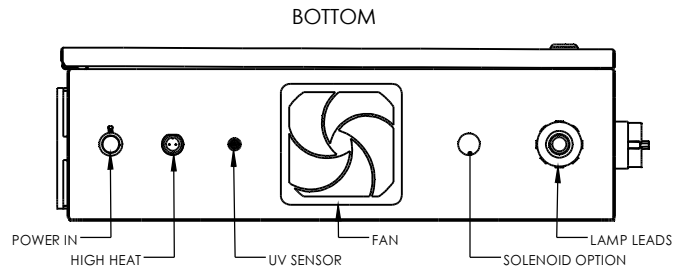
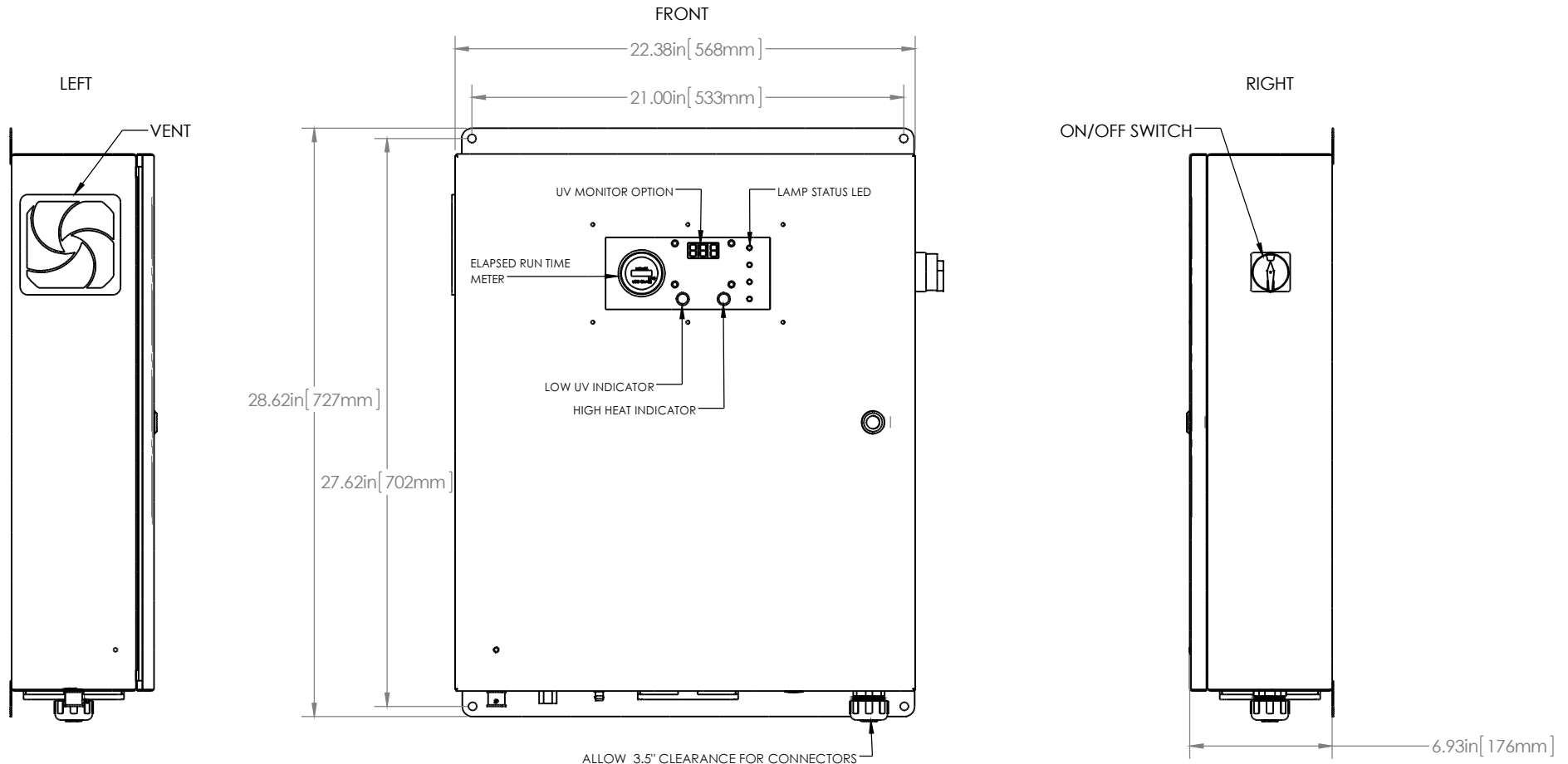

UV Superstore, Inc.
 820 Tucker Ct.
 Winder, GA 30680
 P: 770.307.3882 F: 770.307.3872
www.uvsuperstore.com

TITLE:
 COYOTE, AMALGAM, HIGH HEAT, UV MONITOR

MATERIAL:
 304 STAINLESS STEEL

THE INFORMATION CONTAINED IN THIS DRAWING IS THE SOLE PROPERTY OF UV SUPERSTORE, INC. ANY REPRODUCTION IN PART OR AS A WHOLE WITHOUT THE WRITTEN PERMISSION OF UV SUPERSTORE, INC IS PROHIBITED.

DWG. NO. ME-CYAX	REV
12-2-15	BY: BC SHEET 1 OF 1