

40" MIN. CLEARANCE REQUIRED FOR LAMP AND QUARTZ REPLACEMENT/REMOVAL

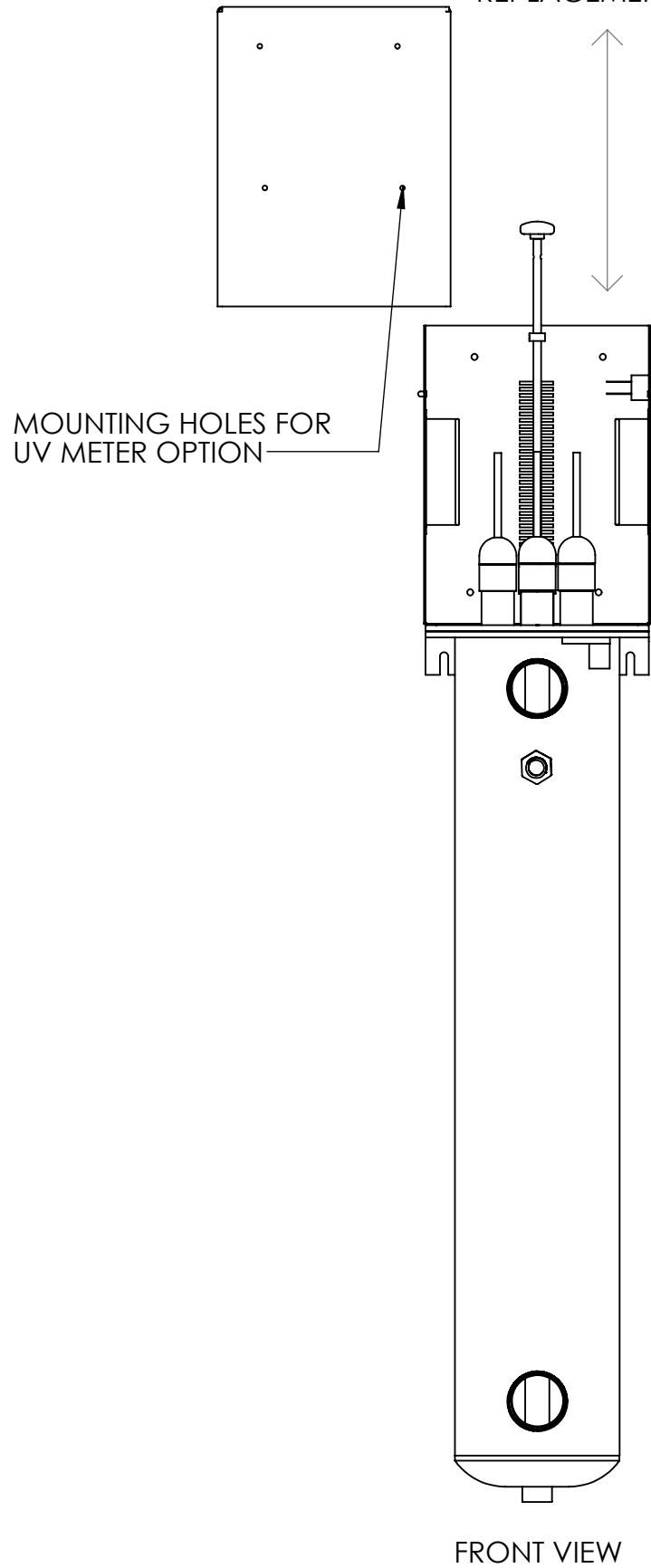

OVERALL LENGTH AND HEIGHT +/- .25"

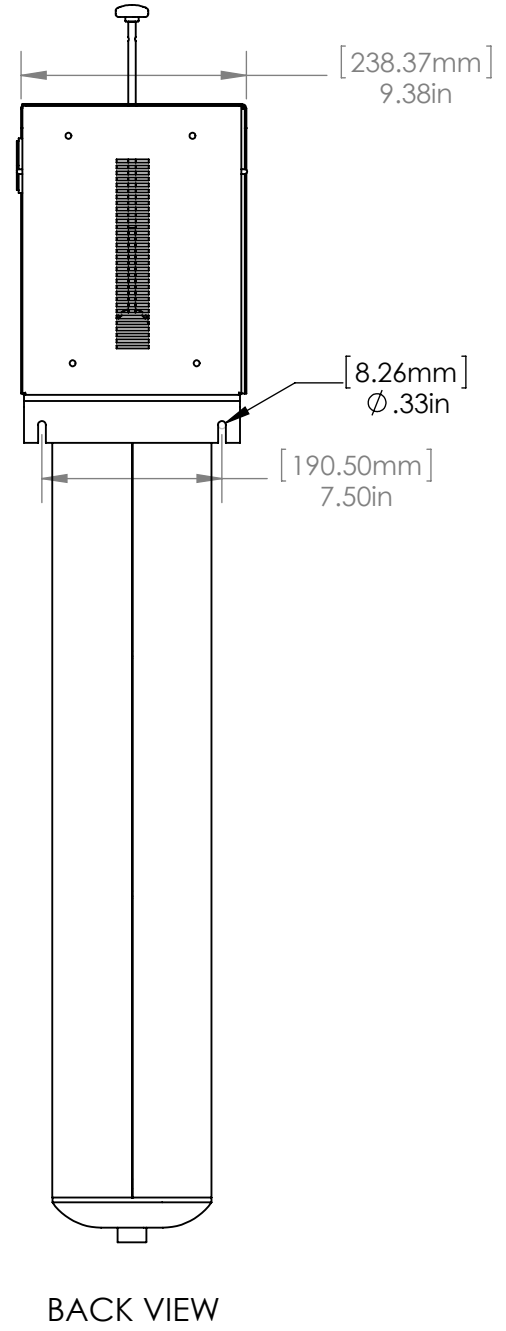
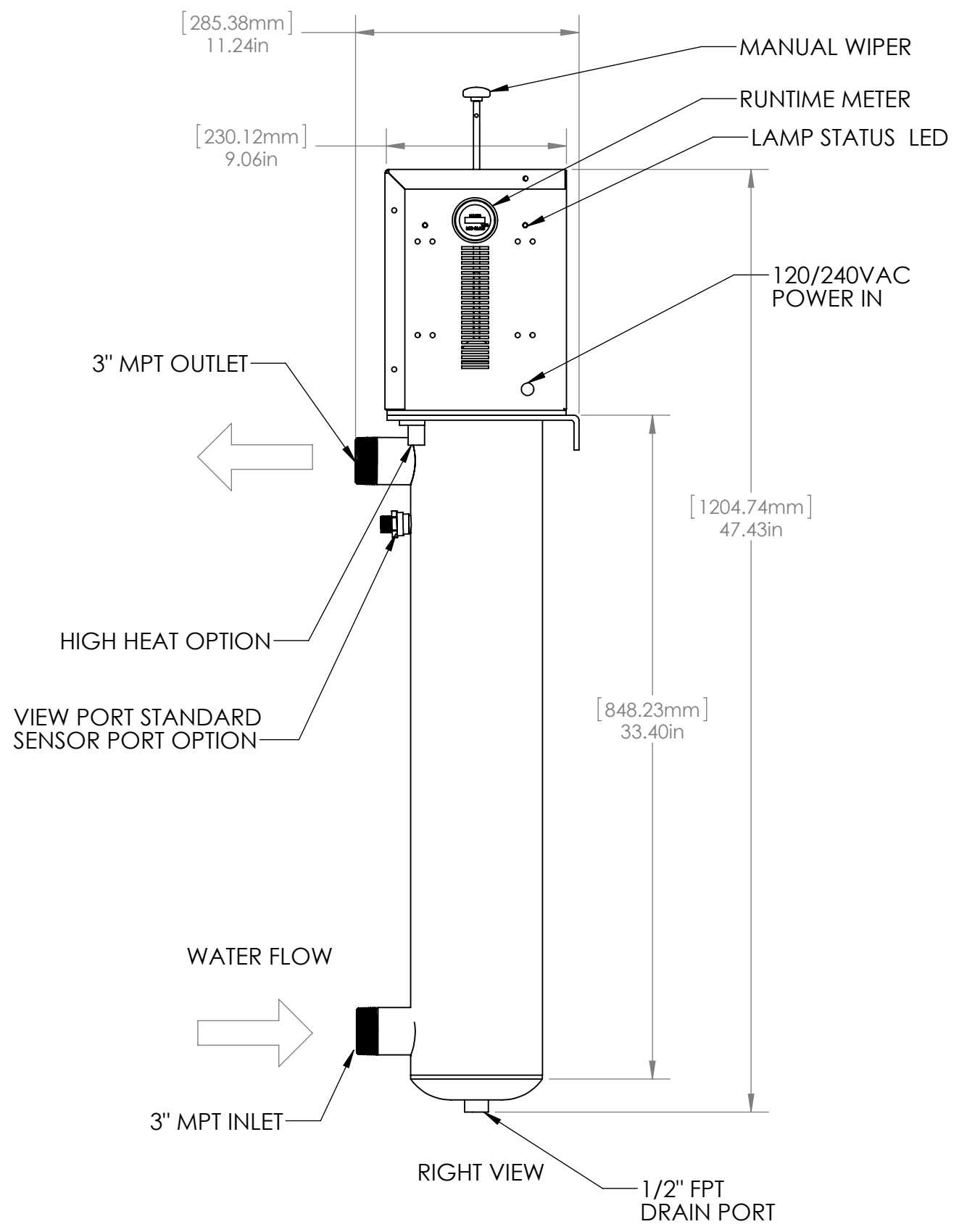

UV Superstore, Inc.
 820 Tucker Ct.
 Winder, GA 30680
 P: 770.307.3882 F:770.307.3872
www.uvsuperstore.com

TITLE:
EAGLE, 4 LAMP, 3" MPT

MATERIAL:
304SS VESSEL, POWDER COATED STEEL ENCLOSURE

THE INFORMATION CONTAINED IN THIS DRAWING IS THE SOLE PROPERTY OF UVSUPERSTORE, INC. ANY REPRODUCTION IN PART OR AS A WHOLE WITHOUT THE WRITTEN PERMISSION OF UVSUPERSTORE, INC IS PROHIBITED.	DWG. NO.	REV
	MV-EG43N	
1-29-16	BY: BC	SHEET 1 OF 1