

40" MIN. CLEARANCE REQUIRED FOR LAMP AND QUARTZ REPLACEMENT/REMOVAL

OVERALL LENGTH AND HEIGHT +/- .25"

MOUNTING HOLES FOR UV METER OPTION

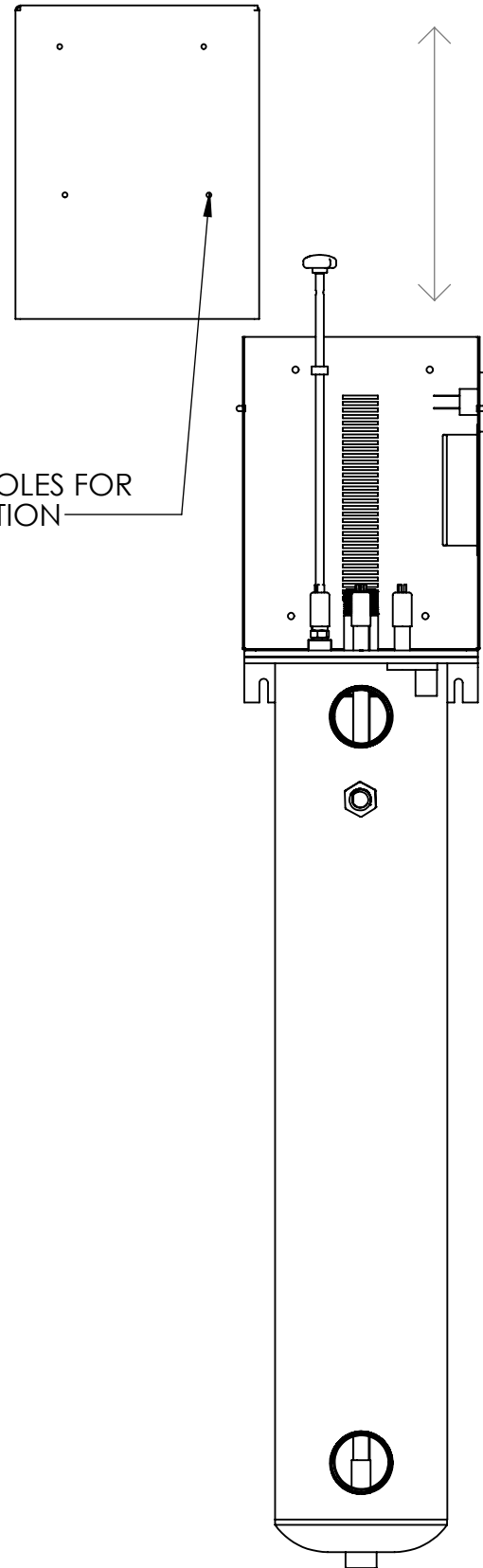

FRONT VIEW

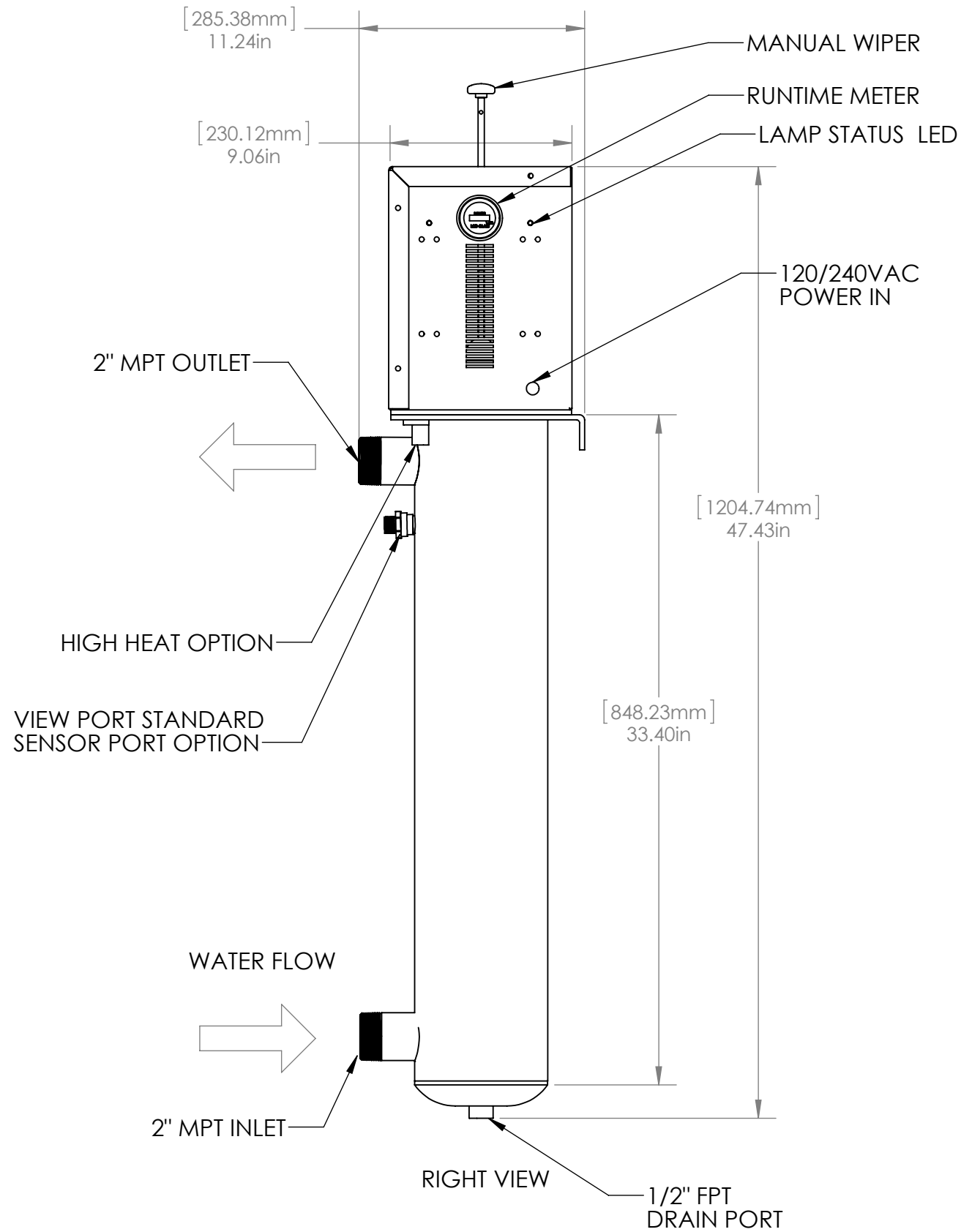

RIGHT VIEW

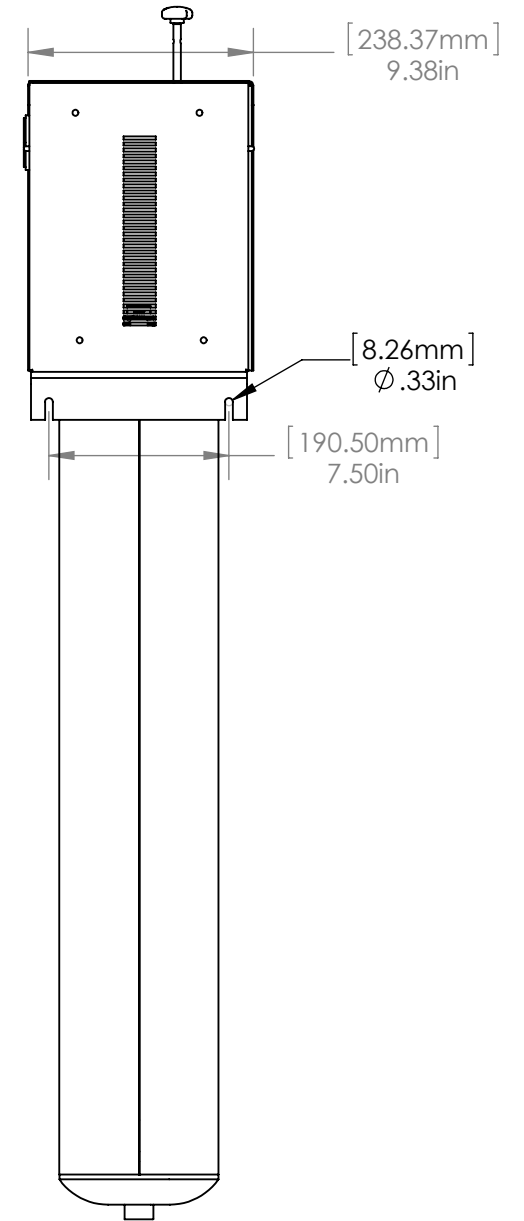

BACK VIEW



UV Superstore, Inc.
 820 Tucker Ct.
 Winder, GA 30680
 P: 770.307.3882 F:770.307.3872
www.uvsuperstore.com

TITLE:
EAGLE, 1 LAMP, 2" MPT

MATERIAL:
304SS VESSEL, POWDER COATED STEEL ENCLOSURE

THE INFORMATION CONTAINED IN THIS DRAWING IS THE SOLE PROPERTY OF UVSUPERSTORE, INC. ANY REPRODUCTION IN PART OR AS A WHOLE WITHOUT THE WRITTEN PERMISSION OF UVSUPERSTORE, INC IS PROHIBITED.

DWG. NO. REV

MV-EG12N

1-29-16

BY: BC

SHEET 1 OF 1